



WARN Industrial Winch

Model

**Series 12-A-2D
Electric Winch
Manual Clutch**

Part Number

30290

Motor Type

DC Electric
24 Volt
Series Wound

The Series 12 DC features a weatherproof industrial contactor and heavy duty remote control. The disc brake is designed for extended power-out use and the motor is protected by a thermal over-load switch. Designed to meet SAE J706 and CE standards.

*Remote Control Assembly, 10m included



Accessories

Description:	Part Number
Wire Rope Tension Plate 10"	31149
Fairlead Black 10"	24336
Fairlead Chrome 10"	30859
Remote Clutch Mechanical	38316
Remote Clutch Air	71370
Wire Rope Assembly 7/16"x100' EIPS	23678

Engineering Data

Rated Pulling Force:	12000 lbf	5443 kgf
Drum Barrel Diameter:	4.0 in	102 mm
Drum Flange Diameter:	8.24 in	209 mm
Distance Between Flanges:	9.95 in	253 mm
Recommended Maximum Wire Rope Diameter:	1/2 in	12.7 mm
Recommended Minimum Wire Rope Breaking Strength:	20400 lbf	9253 kgf
Approximate Shipping Weight:	101.0 lb	45.8 kg
Duty Cycle (intermittent per SAE J706 section 6.2):	60 ft	18.3 m
Mounting Bolt Torque:	35 - 40 ft*lbf	47 - 54 N*m
Maximum Layers of Wire Rope:	4 (with 7/16" dia. rope)	
Gear Reduction:	261:1	
Brake Type:	Disk	
Contactor / Remote Type: Industrial contactor with 33' (10m) heavy duty remote		

Drum Rotation

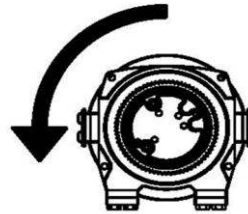

Viewed from Motor End

Standards Compliance

1. -SAE J706
2. -CE Machinery Directive 98/37/EC and 2006/42/EC
3. -CE Electromagnetic Compatibility 2004/108/EC

Performance By Layer- 7/16" (11.1 mm) dia. rope

Drum Layer	Line Load *			No Load Line Speed		Drum Capacity	
	lbf	kgf	kN	ft/min	m/min	ft	m
1	12000	5443	53.4	18.1	5.5	23	7.0
2	10024	4547	44.6	21.6	6.6	51	15.5
3	8606	3904	38.3	25.2	7.7	84	25.6
4	7540	3420	33.5	28.7	8.7	121	36.9

* Never exceed the Rated Pulling Force. Installation of a Rated Capacity Limiter is recommended.

First Layer Performance

Line Load		Current Draw	Line Speed		Duty Cycle
lbf	kgf	Amps	ft/min	m/min	min/10min
0	0	49.0	18.1	5.5	5.6
2000	907	91.0	15.4	4.7	2.4
4000	1814	125.0	12.2	3.7	1.6
6000	2722	160.0	10.5	3.2	1.2
8000	3629	189.0	9.3	2.8	1.0
10000	4536	226.0	7.9	2.4	0.8
12000	5443	249.0	7.0	2.1	0.8

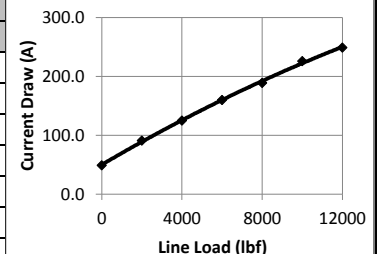
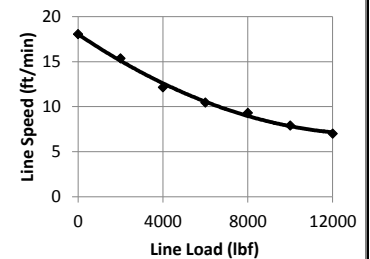

WARN INDUSTRIES, INC
Industrial Products

Customer Service (North America): 1.800.543.9276
Customer Service (International): 1.503.722.3008
FAX: 1.503.722.3000 www.warn.com

12900 S.E. Capps Road,
Clackamas, OR USA 97015



WARN Industrial Winch

Model	Part Number	Motor Type
Series 12-A-2D Electric Winch Manual Clutch	30290	DC Electric 24 Volt Series Wound

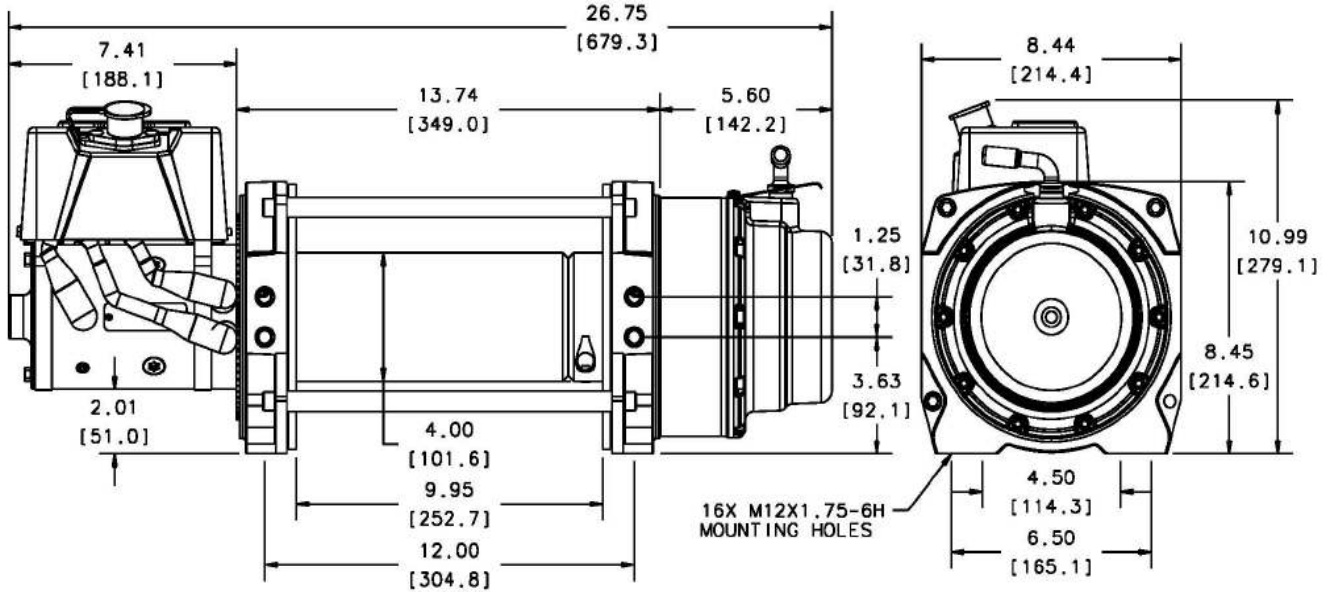

Motor / Contactor may be rotated in 90 degree increments. Clutch housing may be rotated in 72 degree increments.

Units are given in inches [millimeters], unless otherwise specified

Recommended Mounting- Always Observe Correct Drum Rotation

Electrical System Specifications

Pull from bottom of winch

Pull from bottom of winch

Pull from top of winch

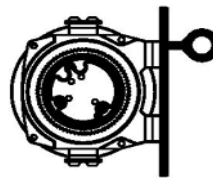
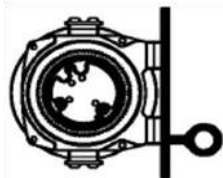

Feet down

Feet forward

Feet forward

Pull from top of winch

Pull from top of winch

Pull from top of winch

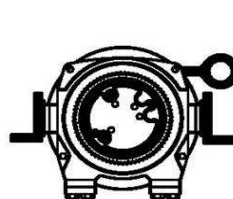

Feet down without angle brace

Feet down with angle brace

Angle Braces Only

- 650 CCA Battery Minimum
- See Electrical Cable Gauge Size Chart for cable sizing
- All electrical connections must be clean and tight

Electrical System Wiring Schematic

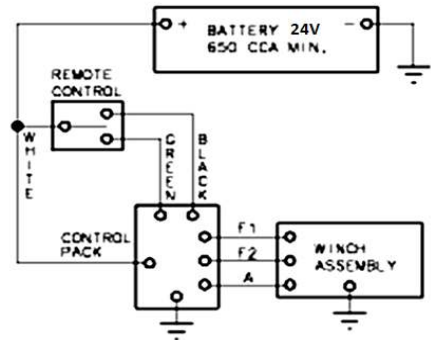

Notes:

WARN INDUSTRIES, INC
Industrial Products

Customer Service (North America): 1.800.543.9276
Customer Service (International): 1.503.722.3008
FAX: 1.503.722.3000 www.warn.com

12900 S.E. Capps Road,
Clackamas, OR USA 97015