



Ramsey Winch Company
OWNER'S MANUAL
Front Mount Electric Winches
Model RE 8,000
Model RE 10,000
Model RE 12,000
Model RE 12,000X



RE 8000					
LAYER OF CABLE	1	2	3	4	5
RATED LINE PULL PER LAYER (LBS) (KGS)	8,000 3,620	6,800 3,080	6,000 2,710	5,300 2,400	4,800 2,170
CABLE CAPACITY PER LAYER (FT)* 5/16 DIA. (M)*	20 6	50 15	80 24	120 36	150 45
LINE PULL FIRST LAYER (LBS) (KGS)	0 0	2,000 900	4,000 1,810	6,000 2,710	8,000 3,620
LINE SPEED FIRST LAYER FPM MPM	15 4.5	7.5 2.2	5.5 1.6	4 1.2	3 0.9
AMP DRAW FIRST LAYER 12V 24V	73 36	155 75	215 105	285 140	345 170



RE 10,000						
LAYER OF CABLE	1	2	3	4		
RATED LINE PULL PER LAYER (LBS) (KGS)	10,000 4,530	8,300 3,750	7,200 3,260	6,300 2,850	6,300 2,850	
CABLE CAPACITY PER LAYER (FT)* 3/8 DIA. (M)*	20 6	40 12	70 21	100 30	100 30	
LINE PULL FIRST LAYER (LBS) (KGS)	0 0	2,000 900	4,000 1,810	6,000 2,710	8,000 3,620	10,000 4,530
LINE SPEED FIRST LAYER FPM MPM	14 4.2	7 2.1	5 1.5	4 1.2	3.5 1	2.5 0.7
AMP DRAW FIRST LAYER 12V 24V	70 30	110 50	180 85	230 110	280 135	330 160

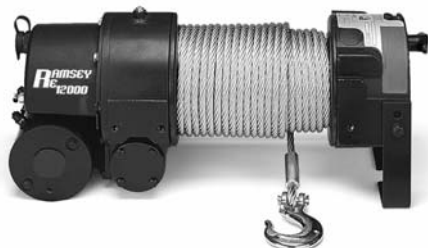

RE 12,000/12,000X						
LAYER OF CABLE	1	2	3	4		
RATED LINE PULL PER LAYER (LBS) (KGS)	12,000 5,430	10,000 4,530	8,600 3,890	7,500 3,390	7,500 3,390	
CABLE CAPACITY PER LAYER (FT)* 3/8 DIA. (M)*	20 6	40 12	70 21	100 30	100 30	
CABLE CAPACITY PER LAYER (FT)* 3/8 DIA. (M)*	25 7	60 18	95 28	125 38	125 38	
LINE PULL FIRST LAYER (LBS) (KGS)	0 0	2,000 900	4,000 1,810	6,000 2,710	8,000 3,620	10,000 4,530
LINE SPEED FIRST LAYER FPM MPM	14 4.2	7 2.1	5 1.5	4 1.2	3.5 1	2.5 0.6
AMP DRAW FIRST LAYER 12V 24V	70 30	110 50	180 85	230 110	280 135	330 160

Ramsey performance data is compiled from actual winch testing.

*DEPENDS ON WIRE ROPE BEING UNIFORMLY WOUND ONTO DRUM.

Congratulations

You have purchased the finest winch available in its service class. It features a strong worm and gear drive to provide load reversing protection. An exclusive semi-automatic RAM-LOK™ clutch disengages for free spooling and is spring loaded for positive engagement. It was designed and manufactured to provide you with the utmost in utility. As with any device that combines power and movement in its use, there are dangers if improperly used. At the same time, there are easier and faster ways for getting the job done if certain precautions are taken first. Please read this manual carefully. It contains useful ideas in obtaining the most efficient operation from your Ramsey Winch and safety procedures you need to know before beginning use. When you follow our guidelines for operation, your Ramsey Winch will give you many years of satisfying service. Thank you for choosing Ramsey. You will be glad you have one working for you.

Contents

Safety Precautions	Front Cover
Tips for Safe Operation	2
Techniques of Operation	2
Installation	3
Operating Instructions	4
Electrical Connections/Operations	4
Lubrication/Cable Installation	4
Trouble Shooting Guide	4-5
Winch Parts List	6-8
Solenoid Parts List/Fairleads/Switch	9
Warranty	Back Cover

Please Note: Ramsey RE 8000, RE 10,000 and RE 12,000 series winches are designed for front mount vehicle use. The winches are not designed for and should not be used in industrial applications (car haulers /carriers, wreckers, hoisting, etc.), and Ramsey does not warrant them to be suitable for such use. Ramsey makes a separate, complete line of winches for industrial/commercial use. Please contact the factory for additional information.

CAUTION: Read and understand this manual before installation and operation of winch. See Safety Precautions.



Safety Precautions To Guard Against Possible Injury.....

A minimum of five wraps of cable around the drum barrel is necessary to hold the rated load. Cable clamp is not designed to hold the load.

- A. Keep yourself and others a safe distance to the side of the cable when pulling under load.
- B. Do not step over a cable, or near a cable under load.
- C. Use supplied hook strap when handling hook for spooling wire rope.
- D. Do not move the vehicle to pull a load on the winch cable. This could result in cable breakage and/or winch damage.
- E. Use a heavy rag or gloves to protect hands from burrs when handling winch cable.
- F. Apply blocks to wheels when vehicle is on an incline.
- G. Winch clutch should be disengaged when winch is not in use and fully engaged when in use.
- H. Modification, alteration, or deviation to the winch should only be made by Ramsey Winch Company.
- I. Keep the duration of your pulls as short as possible. If the motor becomes uncomfortably hot to the touch, stop and let it cool for a few minutes. Do not pull more than one minute at or near the rated load. Do not maintain power to the winch if the motor stalls. Electric winches are for intermittent usage and should not be used in constant duty applications.
- J. Disconnect the remote control switch from the winch when not in use. A Ramsey Part No. 282053 battery disconnect switch in your vehicle is recommended.
- K. Do Not use winch in hoisting applications due to required hoist safety factors and features.
- L. Do not exceed maximum line pull ratings shown in tables. Shock loads must not exceed these ratings.
- M. To respool correctly, it is necessary to keep a slight load on the cable. This is accomplished by (wearing gloves) holding the cable with one hand and the remote control with the other, starting as far back and in the center as you can, walking up keeping load on the cable as the winch is powered in. Do not allow the cable to slip through your hand and do not approach the winch too closely. Turn off the winch and repeat the procedure until all the cable except a few feet is in. Disconnect the

remote control switch and finish spooling in cable by rotating the drum by hand with clutch disengaged. On hidden winches, spool in cable under power using supplied hook strap.



Tips for Safe Operation

Do not underestimate the potential danger in winching operations. Neither should you fear them. Do learn the basic dangers and avoid them.

The uneven spooling of cable, while pulling a load, is not a problem, unless there is a cable pileup on one end of drum. If this happens, reverse the winch to relieve the load and move your anchor point further to the center of the vehicle. After the job is done you can unspool and rewind for a neat lay of the cable.

Store the remote control switch inside your vehicle where it will not become damaged. Inspect it before you plug it in.

When ready to begin spooling in, plug in remote control switch with clutch disengaged. Do not engage clutch with motor running.

Never connect the hook back to the cable. This causes cable damage. Always use a sling or chain of suitable strength as shown in the illustration, page 3.

Observe your winch while winching, if possible, while standing at a safe distance. If you use vehicle drive to assist, stop and get out every few feet to assure the cable is not piling up in one corner. Jamming cable can break your winch.

Do not attach tow hooks to winch mounting apparatus. They must attach to vehicle frame.

When double lining during stationary winching, the winch hook should be attached to the chassis of the vehicle.

Since the greatest pulling power is achieved on the innermost layer of your winch, it is desirable to pull off as much line as you can for heavy pulls. Remember, a minimum of 5 wraps of cable around the drum barrel is necessary to hold the rated load.

If this is not practical, use a snatch block and double line arrangement as shown in the illustration, page 3. Neat, tight spooling avoids cable binding. Cable binding occurs when a cable under load pulls down into the layer below, becoming pinched between two other wraps of cable. If this happens, alternately power the winch in and out a few inches. Do not attempt to work a bound cable under load; free by hand.

Techniques of Operation

The best way to get acquainted with how your winch operates is to make a few test runs before you actually need to use it. Plan your test in advance. Remember you hear your winch as well as see it operate. Get to recognize the sound of a light steady pull, a heavy pull, and sounds caused by load jerking or shifting. Soon you will gain confidence in operating your winch and its use will become second nature with you.

When pulling a heavy load, place a blanket, jacket or tarpaulin over the cable five or six feet from the hook. It will slow the snap back in the event of a broken cable. Also, open the vehicle hood for additional protection.

Use the vehicle wheel power to help the winch, but do not overtake the winch line. Plan your pull. You can not always hook up and pull out in one step. Examine the area for anchoring possibilities as well as leverage situations, direction, and goal.

Your winch will not only pull you up or ease you down a steep grade, it will also pull another vehicle or a load while your vehicle is anchored in a stationary position. The following illustrations show a few basic winching techniques.

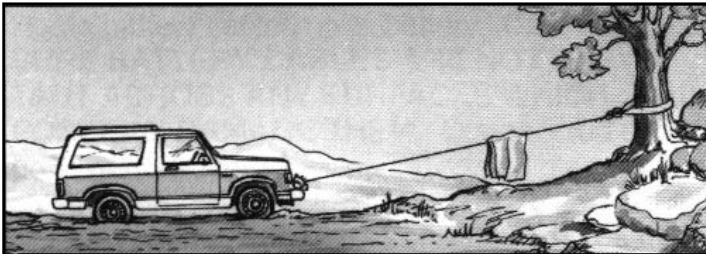

For basic self recovery, anchor to a tree or heavy rock. When anchoring to a tree, always use a tree trunk protector.

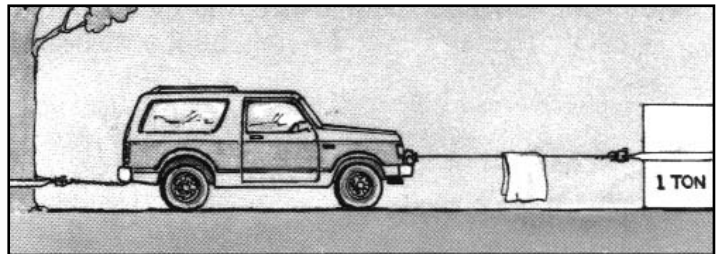

For a direct pull of 2,000 lbs., hitch truck to a tree or solid anchor, and take out of gear.



Stakes driven in solid earth and chained together make a good anchor point for self-recovery when no solid anchor point is available.

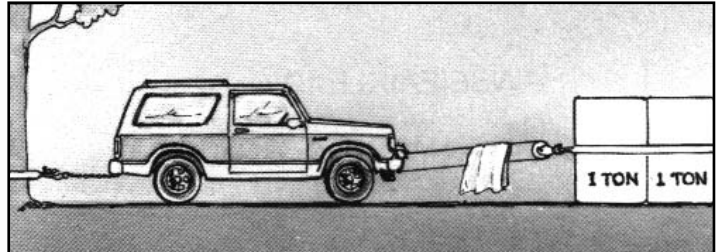

To double the pull, use 2-part line with snatch block and tie off to chassis. Take out of gear.

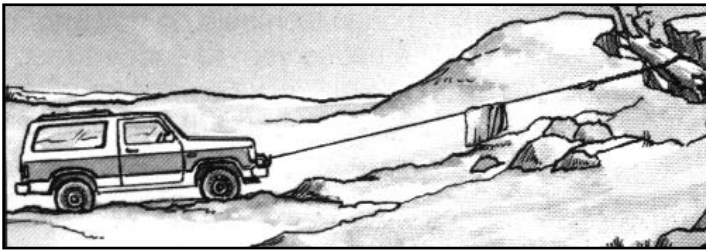

For a solid anchor, bury a log with earth or sand or place it in a deep ravine

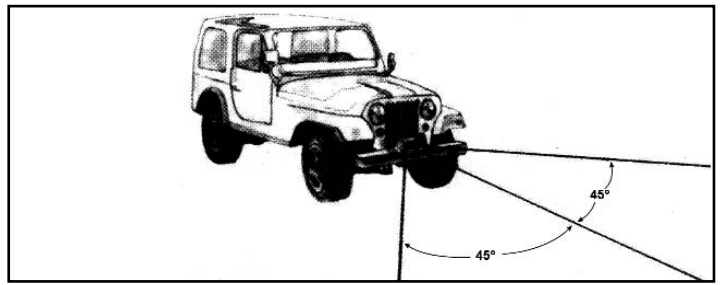

Winches equipped with cable guide fairleads can pull from several directions. Pull from an angle only to straighten up the vehicle—otherwise you can damage structural members or other parts of your vehicle and cause excess cable buildup on one end of the winch drum.

Installation

Winches shown in this owner's manual are solely and exclusively designed for vehicle mounted, non-industrial applications. Use in other applications will void warranty.

It is recommended that Ramsey mounting kits be used to mount the winch. They are designed to align the winch and distribute up to the full rated load correctly to avoid possible damage to the winch or the vehicle. **NOTE:** If Ramsey kits are not used, the winch must be mounted to angles (3/8 x 2 1/2 x 3 min.) or in a frame with both sides of the clutch housing and gear housing bolted to the angles or frame. See below for dimensions.

Substitution of attaching hardware items (bolts, nuts, or washers) different from those supplied with your winch mounting kit can lead to failure causing damage or serious injury. (Use SAE grade 5 bolts or better). See diagram below for recommended mounting dimensions.

Electrical Connections and Operations

For normal self recovery work, your existing electrical system is adequate. Your battery must be kept in good condition. A fully charged battery and proper connections are essential. Run the vehicle engine during winching operation to keep the battery charged.

Connect red cable to battery positive (+) terminal and stud on plastic solenoid cover on winch. **IMPORTANT:** Hold inner nut with open end wrench while tightening outer nut.

Connect black cable to negative (-) terminal of battery and to winch mounting bolt nearest drum, as shown below. A good electrical ground is required for proper performance.

The remote control switch is water proof and practically indestructible. It has push button stations on either side. It is designed this way to prevent quick winch reversals which lead to solenoid failure. Make sure the winch motor has stopped fully before reversing.

When first setting up your winch, follow the directions for inserting the proper "IN" or "OUT" sign in the thumb button. The switch is also color coded to aid you in not having to guess at the direction your winch will run. Pushing both buttons at the same time will not damage your winch in any way.

DO NOT LEAVE SWITCH PLUGGED IN WHEN WINCH IS NOT IN USE.

Cable Installation

1. Unwind cable by rolling it out along the ground to prevent kinking. Securely wrap end of cable opposite hook, with plastic or similar tape to prevent fraying.
2. Insert the end of the cable, opposite hook end, under drum and into the 7/16" dia. hole in drum barrel. Secure cable to drum barrel, using setscrew provided with winch. **TIGHTEN SETSCREW SECURELY.**
3. Carefully run winch in the "reel-in" direction. Keeping tension on end of cable, spool all the cable onto drum, taking care to form neatly wrapped layers.

Inspect the cable frequently. If the cable becomes frayed with broken strands, replace immediately. Cable and hook assemblies may be purchased from a Ramsey distributor.

Operating Instructions

The RAM-LOK™ semi-automatic clutch provides free spooling and clutch engagement with cable drum. With the clutch disengaged, the cable can be pulled off the drum by hand. For winching in the load, the clutch must be fully engaged with the drum.

To disengage the clutch, run the winch in the reverse (reel-out) direction until the load is off the cable and the cable drum stops turning. Pull outward on the clutch handle, rotate it counterclockwise 90° and release. The clutch is now locked out and the cable may be pulled off by hand. (*Note:* If the clutch handle can not be pulled out, again run the winch momentarily in reverse to relieve pressure on the clutch jaws).

Warning: Do not attempt to disengage the cable drum when there is a load on the cable.

Maintenance

Check monthly the action of the sliding clutch, making sure it is fully engaging and disengaging with the cable drum. With the clutch in the engaged position, remove the plastic plug in top of the housing and observe if the clutch is fully engaging. If clutch is not fully engaging, inspect clutch shifter assembly parts, check for damage or excessive wear and replace as necessary. Observe the jaws on both the clutch and cable drum, checking for rounding of the drive faces. If rounding has occurred, they should be replaced immediately.

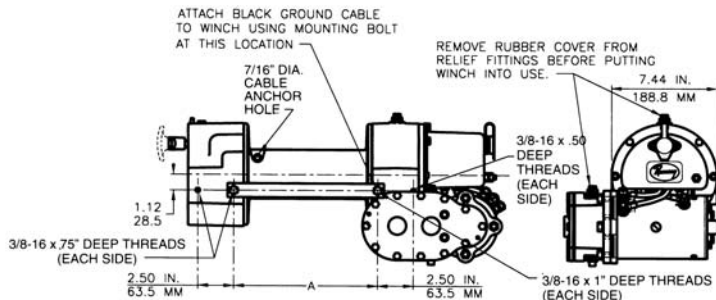

Model	"A" Dimension	
	In. ± .015	MM ± .4
RE 8000	10.12	257.2
RE 10,000	10.12	257.2
RE 12,000	10.12	257.2
RE 12,000X	13.12	333.3

To preserve original appearance, wax periodically.
Spool the cable properly on the drum when storing between each usage.

Check the oil level in the gear boxes every six months. At the same time, check electrical connections and mounting bolts - tighten if necessary.

Corrosion on electrical connections will reduce performance or may cause a short. Clean all connections, especially in remote switch receptacle. In salty environments use a silicone sealer to protect from corrosion.

Be sure the winch has plenty of battery power available.

Replace oil annually, or more often if winch is used frequently.

For RE 8000:

Fill the worm gear box with 3/4 pint of Phillips SMP 80W-90, Mobil HD 80W-90, or Shell Spirax HD 80W-90.

For RE 10000, RE 12000, and RE 12000X:

Use 3/4 pint of SAE 140 EP.

Use 1/2 pint of SAE 20 in spur gear box (all RE series winches). Apply cup grease to lube fitting at top of clutch housing. Should winch be submerged for a brief period, drain oil, flush and replace oil in gear boxes, and grease all fittings (see Troubleshooting Guide below).

Ramsey Electric Winches Troubleshooting Guide

CONDITION	POSSIBLE CAUSE	CORRECTION
MOTOR RUNS IN ONE DIRECTION ONLY	(1) Inoperative solenoid or stuck solenoid (2) Inoperative remote control switch	(1) Jar solenoid to free contacts. Check by applying 12 volts to coil terminal (it should make an audible click when energized). (2) Disengage winch clutch, remove remote control switch plug from the socket and jump pins at 8 and 4 o'clock. Motor should run. Jump pins at 8 and 10 o'clock. Motor should run.
MOTOR RUNS EXTREMELY HOT MOTOR RUNS, BUT WITH INSUFFICIENT POWER, OR WITH LOW LINE SPEED	(1) Long period of operation (2) Insufficient battery (3) Electrical cable from battery to winch or ground strap from engine block to vehicle chassis too small. (4) Bad electrical connections (5) Insufficient charging system	(1) Cooling-off periods are essential to prevent overheating. (2) Check battery terminal voltage under load. If 10 volts or less, replace or parallel another battery to it. (3) Must be No. 2 equivalent (or larger if longer than 15 ft.). (4) Check all connections for looseness or corrosion; tighten, clean and grease. (5) Replace with larger capacity charging system.
MOTOR RUNS, BUT DRUM DOES NOT TURN	(1) Clutch not engaged (2) Sheared drum shaft key (3) Stripped bronze gear (4) Parted shaft	(1-4) If clutch engaged but symptom still exists, it will be necessary to disassemble winch to determine cause and repair.
MOTOR WILL NOT OPERATE	(1) Inoperative solenoid or stuck solenoid (2) Inoperative remote control switch (3) Inoperative motor (4) Loose connections	(1) Jar solenoid to free contacts. Check by applying 12 volts to coil terminal (it should make an audible click when energized). (2) Disengage winch clutch, remove remote control switch plug from the socket and jump pins at 8 and 4 o'clock. Motor should run. Jump pins at 8 and 10 o'clock. Motor should run. (3) If solenoids operate, check for voltage at armature post; replace motor. (4) Tighten connections on bottom side of hood and on motor.
MOTOR WATER DAMAGED	(1) Submerged in water or water from high pressure car wash	(1) Allow to drain and dry thoroughly, then run motor without load in short bursts to dry windings
CLUTCH INOPERATIVE OR BINDS UP	(1) Dry or rusted shaft (2) Dog point setscrew too tight (3) Bent yoke (4) Keys pulled out of shape by overload	(1) Clean and lubricate (2) Remove rubber plug from clutch housing and rotate setscrew outward until clutch operates smoothly. Replace rubber plug. (3) Replace yoke or shifter assembly (4) If drum shaft keyways are rounded or damaged replace shaft and keys. If not, file off burrs and replace keys.
CLUTCH SPRING DOES NOT OPERATE	(1) Broken spring	(1) Replace
CLUTCH DOES NOT LOCK AT DISENGAGED POSITION	(1) Setscrew loose or worn	(1) Remove rubber plug from clutch housing, tighten setscrew or replace. Replace plug.
OIL LEAKS FROM HOUSING	(1) New seal (2) Seal damaged or worn (3) Too much oil (4) Damaged gasket	(1) New seals sometimes leak until seated to shaft. (2) Replace. (3) Drain excess oil per lubrication instructions. (4) Replace.

RE 8000™

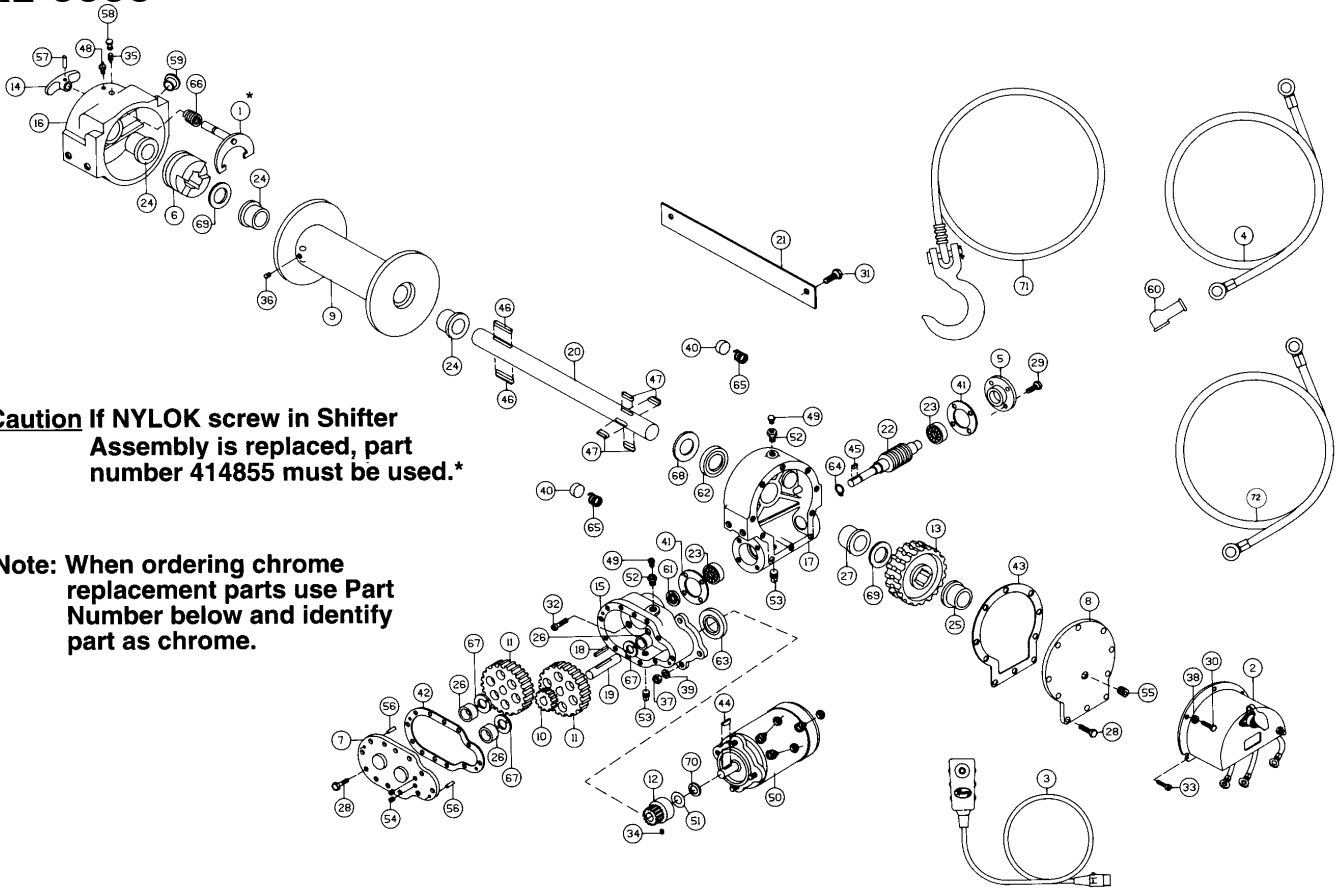

Caution If NYLOK screw in Shifter Assembly is replaced, part number 414855 must be used.*

Note: When ordering chrome replacement parts use Part Number below and identify part as chrome.

Winch Parts List RE 8000

(Continued)

Item No.	Qty. Req'd	Part No.	Description
1	1	276028	Shifter Assembly*
2	1	278027	Solenoid Assembly-12V
	1	278028	Solenoid Assembly-24V
3	1	282001	Switch Assembly
4	1	289015	Battery Cable-Red
5	1	316083	Bearing Cap
6	1	324137	Jaw Clutch
7	1	328106	Cover-Spur Gear Hsg.
8	1	328134	Cover-Worm Gear Hsg.
9	1	332136	Cable Drum
10	1	334001	Idle Gear
11	2	334003	Spur Gear
12	1	334129	Pinion Gear
13	1	334168	Gear R.H.-46:1
14	1	336010	Handle
15	1	338203	Spur Gear Housing
16	1	338208	Clutch Housing
17	1	338273	Gear Housing
18	1	342033	Key
19	1	356901	Shaft-Spur
20	1	357484	Shaft-Drum
21	1	364029	Strap
22	1	368162	Worm-R.H.-46:1
23	2	402002	Bearing-Ball
24	3	412003	Bushing
25	1	412040	Bushing
26	3	412038	Bushing
27	1	412047	Bushing
28	17	414038	Capscrew 1/8-20NC x 3/4 Lg. Hx.Hd. Gr. 5
29	4	414045	Capscrew 1/8-20NC x 1/2 Lg. Hx.Hd. Gr. 5
30	3	414059	Capscrew 1/8-20NC x 1 Lg. Hx.Hd. 7.P. Gr. 5
31	2	414279	Capscrew 1/8-16NC x 3/4 Lg. Hx.Hd. Gr. 5
32	4	414845	Capscrew 1/8-20NC x 1 Lg. Soc.Hd. Loc-Wel
33	2	414856	Capscrew 1/8-20NC x 3/4 Lg. Soc.Hd. Z.P.
34	1	416029	Setscrew 1/8-20NC x 3/4 Lg. Soc.Hd.
35	1	416030	Setscrew 1/8-20NC x 1 Lg. Soc.Hd. (Full Dog Pt.)
36	1	416059	Setscrew 1/8-16NC x 1/2 Lg. Soc.Hd.

Item No.	Qty. Req'd	Part No.	Description
37	3	418040	Nut 1/8-24NF Hx.Reg. Z.P.
38	3	418154	Washer 1/8 Flat Alum.
39	3	418177	Lockwasher- 1/8 Med.Sect. Z.P.
40	2	438014	Drag Brake
41	2	442184	Gasket
42	1	442185	Gasket
43	1	442205	Gasket
44	1	450001	Key
45	1	450005	Key
46	2	450006	Key (Barth)
47	4	450016	Key (Barth)
48	1	456001	Lub Filling
49	2	456008	Relief Fitting
50	1	458001	Motor-12V
	1	458005	Motor-24V
51	1	462015	O-Ring
52	2	468002	Reducer
53	2	468011	Pipe Plug Sq. Hd.
54	2	468017	Pipe Plug Soc.Hd.
55	1	468018	Pipe Plug Soc.Hd.
56	2	470001	Pin
57	1	470033	Spirol Pin
58	1	472012	Plug
59	1	472013	Plug
60	1	482013	Rubber Boot
61	1	486009	Oil Seal
62	1	486017	Oil Seal
63	1	486023	Oil Seal
64	1	490003	Snap Ring
65	2	494002	Spring
66	1	494053	Spring
67	3	518002	Thrust Washer
68	1	518014	Thrust Washer
69	2	518015	Thrust Washer
70	1	518018	Fiber Washer
71	1	251184	Cable & Hook-150' x 3/16" dia.
72	1	289141	Ground Wire-Black

RE 10000™

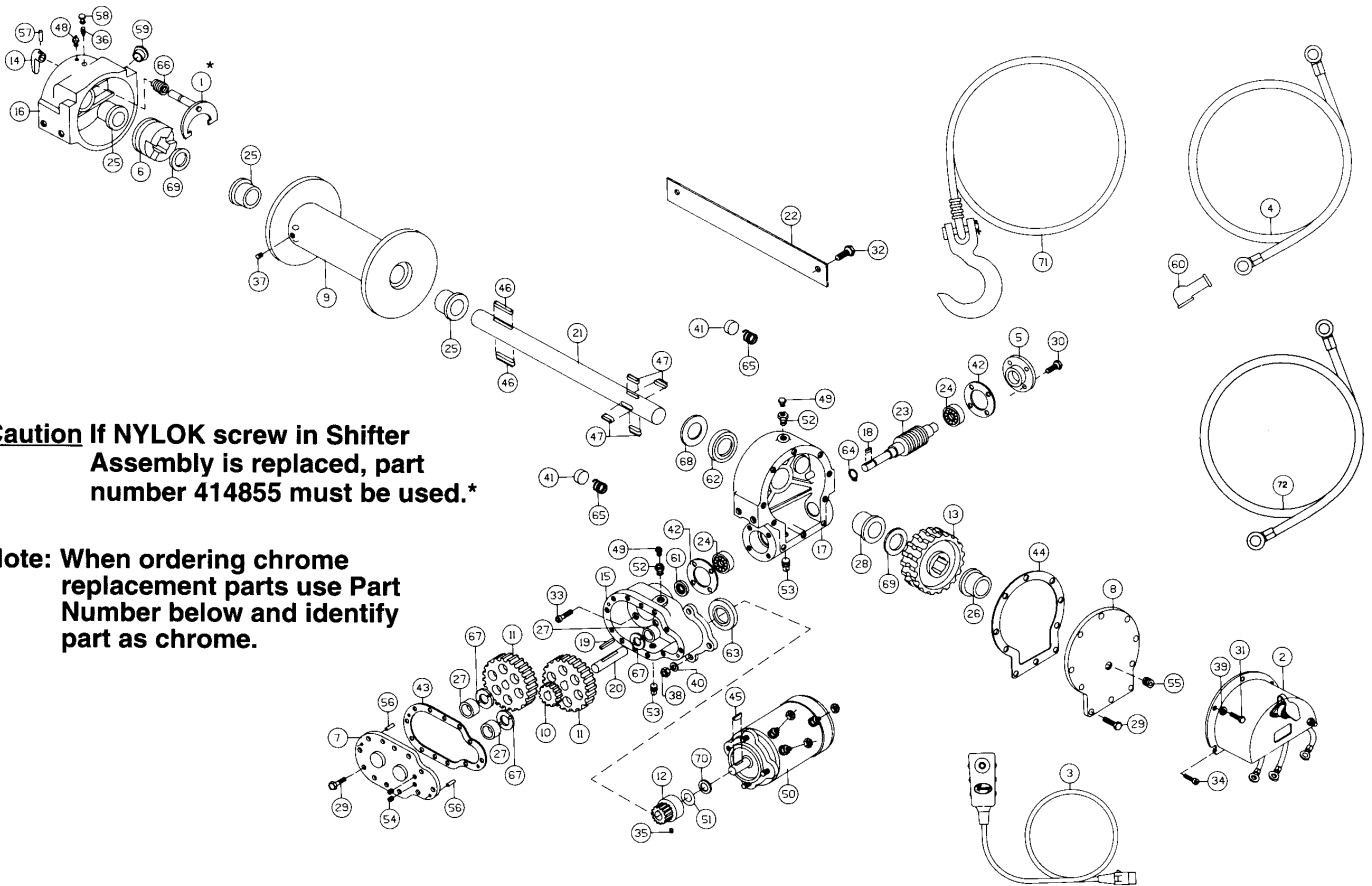

Caution If NYLOK screw in Shifter Assembly is replaced, part number 414855 must be used.*

Note: When ordering chrome replacement parts use Part Number below and identify part as chrome.

Winch Parts List RE 10,000

(Continued)

Item No.	Qty. Req'd	Part No.	Description
1	1	276028	Shifter Assembly*
2	1	278027	Solenoid Assembly-12V
	1	278028	Solenoid Assembly-24V
3	1	282001	Switch Assembly
4	1	289015	Battery Cable-Red
5	1	316083	Bearing Cap
6	1	324137	Jaw Clutch
7	1	328106	Cover-Spur Gear Hsg.
8	1	328134	Cover-Worm Gear Hsg.
9	1	332136	Cable Drum
10	1	334001	Idler Gear
11	2	334003	Spur Gear
12	1	334129	Pinion Gear
13	1	334161	Gear R.H.-60:1
14	1	336021	Handle
15	1	338203	Spur Gear Housing
16	1	338208	Clutch Housing
17	1	338273	Gear Housing
18	1	342023	Key
19	1	342033	Key
20	1	356901	Shaft-Spur
21	1	357484	Shaft-Drum
22	1	364029	Strap
23	1	368001	Worm-R.H.-60:1
24	2	402002	Bearing-Ball
25	3	412003	Bushing
26	1	412040	Bushing
27	3	412038	Bushing
28	1	412047	Bushing
29	17	414038	Capscrew ¼-20NC x ½ Lg. Hx.Hd. Gr. 5
30	4	414045	Capscrew ¼-20NC x ½ Lg. Hx.Hd. Gr. 5
31	3	414059	Capscrew ¼-20NC x 1 Lg. Hx.Hd. Z.P. Gr. 5
32	2	414279	Capscrew ¼-16NC x ½ Lg. Hx.Hd. Gr. 5
33	4	414845	Capscrew ¼-20NC x 1 Lg. Soc.Hd. Loc-Wel
34	2	414856	Capscrew ¼-20NC x ½ Lg. Soc.Hd. Z.P.
35	1	416029	Setscrew ¼-20NC x ½ Lg. Soc.Hd.
36	1	416030	Setscrew ¼-20NC x ½ Lg. Soc.Hd. (Full Dog Pt.)

Item No.	Qty. Req'd	Part No.	Description
37	1	416059	Setscrew ¼-16NC x ½ Lg. Soc.Hd.
38	3	418040	Nut ¼-24NF Hx.Reg. Z.P.
39	3	418154	Washer ¼ Flat Alum.
40	3	418177	Lockwasher-¼ Med.Sect. Z.P.
41	2	438014	Drag Brake
42	2	442184	Gasket
43	1	442185	Gasket
44	1	442205	Gasket
45	1	450001	Key
46	2	450006	Key (Barth)
47	4	450016	Key (Barth)
48	1	456001	Lub Fitting
49	2	456008	Relief Fitting
50	1	458001	Motor-12V
	1	458005	Motor-24V
51	1	462015	O-Ring
52	2	468002	Reducer
53	2	468011	Pipe Plug Sq.Hd.
54	2	468017	Pipe Plug Soc.Hd.
55	1	468018	Pipe Plug Soc.Hd.
56	2	470001	Pin
57	1	470002	Spirol Pin
58	1	472012	Plug
59	1	472013	Plug
60	1	482013	Rubber Boot
61	1	486009	Oil Seal
62	1	486017	Oil Seal
63	1	486023	Oil Seal
64	1	490003	Snap Ring
65	2	494002	Spring
66	1	494053	Spring
67	3	518002	Thrust Washer
68	1	518014	Thrust Washer
69	2	518015	Thrust Washer
70	1	518018	Fiber Washer
71	1	251123	Cable & Hook-100' x ¾" dia.
72	1	289141	Ground Wire-Black

RE 12000/12000X™

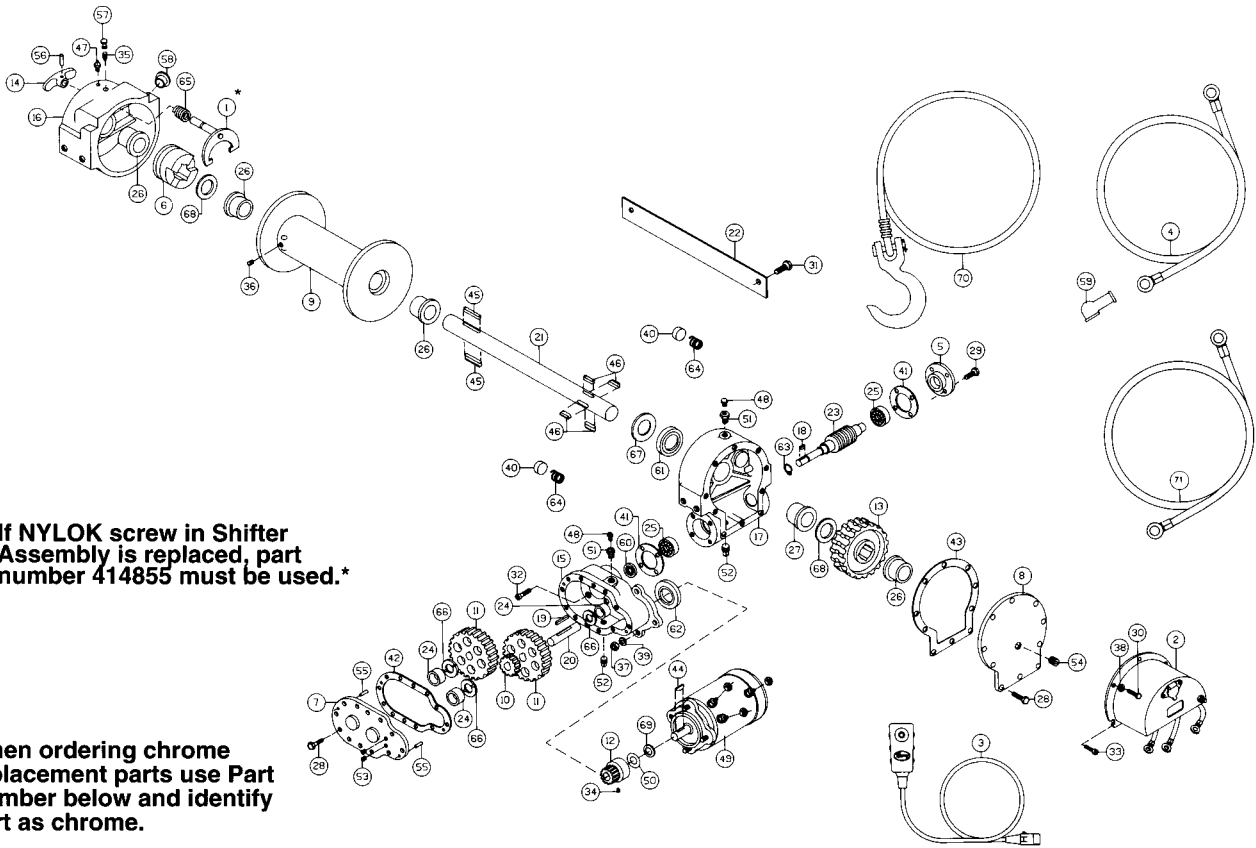

Caution If NYLOK screw in Shifter Assembly is replaced, part number 414855 must be used.*

Note: When ordering chrome replacement parts use Part Number below and identify part as chrome.

Winch Parts List RE 12,000/RE 12,000X (Continued)

Item No.	Qty. Req'd	Part No.	Description	Item No.	Qty. Req'd	Part No.	Description
1	1	276028	Shifter Assembly*	36	1	416059	Setscrew 3/8-16NC x 1/2 Lg. Soc.Hd.
2	1	278027	Solenoid Assembly-12V	37	3	418040	Nut 3/8-24NF Hx.Reg. C.P.
	1	278028	Solenoid Assembly-24V	38	3	418154	Washer 3/8 Flat Alum.
3	1	282001	Switch Assembly	39	3	418177	Lockwasher-3/8 Med.Sect. C.P.
4	1	289015	Battery Cable-Red	40	2	438014	Drag Brake
5	1	316083	Bearing Cap	41	2	442184	Gasket
6	1	324137	Jaw Clutch	42	1	442185	Gasket
7	1	328106	Cover-Spur Gear Hsg.	43	1	442205	Gasket
8	1	328134	Cover-Worm Gear Hsg.	44	1	450001	Key
9	1	332136	Cable Drum	45	2	450006	Key (Barth)
	1	332105	Cable Drum (RE 12,000X)	46	4	450016	Key (Barth)
10	1	334001	Idler Gear	47	1	456001	Lub Fitting
11	2	334003	Spur Gear	48	2	456008	Relief Fitting
12	1	334129	Pinion Gear	49	1	458094	Motor-12V
13	1	334161	Gear R.H.-60:1		1	458005	Motor-24V
14	1	336010	Handle	50	1	462015	O-Ring
15	1	338203	Spur Gear Housing	51	2	468002	Reducer
16	1	338208	Clutch Housing	52	2	468011	Pipe Plug Sq.Hd.
17	1	338273	Gear Housing	53	2	468017	Pipe Plug Soc.Hd.
18	1	342023	Key	54	1	468018	Pipe Plug Soc.Hd.
19	1	342033	Key	55	2	470001	Pin
20	1	356901	Shaft-Spur	56	1	470033	Spirol Pin
21	1	357480	Shaft-Drum	57	1	472012	Plug
	1	357479	Shaft-Drum (RE 12,000X)	58	1	472013	Plug
22	1	364029	Strap	59	1	482013	Rubber Boot
	1	364017	Strap (RE 12,000X)	60	1	486009	Oil Seal
23	1	368001	Worm-R.H.-60:1	61	1	486017	Oil Seal
24	3	402001	Bearing-Needle	62	1	486023	Oil Seal
25	2	402002	Bearing-Ball	63	1	490003	Snap Ring
26	4	412003	Bushing	64	2	494002	Spring
27	1	412045	Bushing	65	1	494053	Spring
28	17	414038	Capscrew 1/4-20NC x 3/4 Lg. Hx.Hd. Gr. 5	66	3	518002	Thrust Washer
29	4	414045	Capscrew 1/4-20NC x 1/2 Lg. Hx.Hd. Gr. 5	67	1	518014	Thrust Washer
30	3	414059	Capscrew 1/4-20NC x 1 Lg. Hx.Hd. C.P. Gr. 5	68	2	518015	Thrust Washer
31	2	414279	Capscrew 3/8-16NC x 1/2 Lg. Hx.Hd. Gr. 5	69	1	518018	Fiber Washer
32	4	414845	Capscrew 1/4-20NC x 1 Lg. Soc.Hd. Loc-Wel	70	1	251123	Cable & Hook-100' x 3/8" dia.
33	2	414856	Capscrew 1/4-20NC x 3/4 Lg. Soc.Hd. C.P.		1	251124	Cable & Hook (RE 12,000X)-125' x 3/8" dia.
34	1	416029	Setscrew 1/4-20NC x 3/4 Lg. Soc.Hd.	71	1	289141	Ground Wire-Black
35	1	416030	Setscrew 1/4-20NC x 3/4 Lg. Soc.Hd. (Full Dog Pt.)				

Solenoid Assembly Parts

278027 - 12V
278028 - 24V

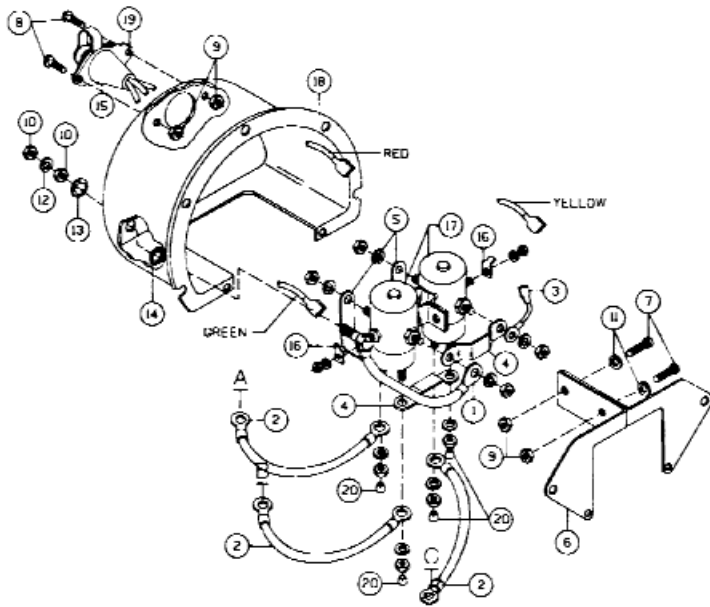

Item No.	Qty. Req'd	Part No.	Description
1	1	280009	Cable-Bolt Ass'y.
2	3	289077	Wire Ass'y.
3	1	289091	Wire Ass'y.
4	2	364001	Strap
5	2	364002	Strap
6	1	408035	Solenoid Bracket
7	2	416216	Screw
8	2	416227	Screw
9	4	418004	Nut
10	2	418022	Nut 1/8-18NC Hx.Reg.
11	2	418140	Flat Washer #10
12	1	418163	Lockwasher 1/4 Med. Sect.
13	1	418164	Lockwasher 1/4 Internal
14	1	418165	Lockwasher 1/4 External
15	1	430013	Female Connector
16	2	440071	Terminal-Tab
17	2	440110	Solenoid-12V
18	1	472071	Cover
19	1	482029	Cover-Connector
20	4	530106	Cover-Terminal

Remote Control Switch #251110

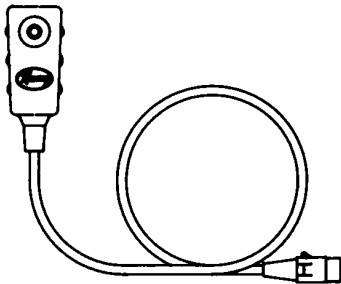

Included with: RE 8000 /RE 10,000 /RE 12,000

Roller Fairlead #251153

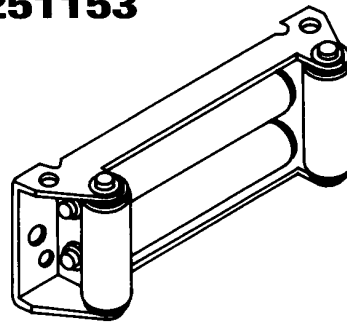

Mounting hardware included with mounting kits

Hawse Fairlead #251152

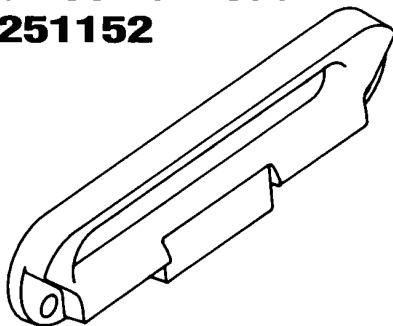

Mounting hardware included with mounting kits

Roller Fairlead #251154

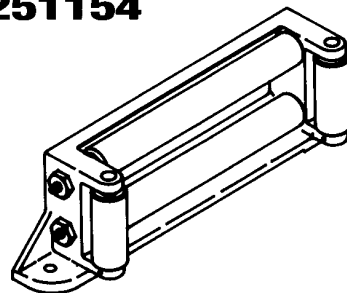

for RE 12,000 XR only

Mounting hardware included with mounting kits

Test Procedure for Solenoids

Steps to follow when testing current flow through DC solenoids.

It should be noted that when testing a 12 volt or 24 volt solenoid, the DC motor and battery must be of the same voltage.

To test the solenoids: (See Figure 1).

1. Securely clamp a motor to a bench or work surface.
2. Attach a jumper wire from (A) terminal on the motor to one of the field terminals on the motor, (F-2).
3. Attach the other motor field terminal (F-1) to one of the side terminals of the solenoid.
4. Ground the solenoid to the motor with a wire as shown.
5. Attach positive (+) battery wire to the opposite side terminal of the solenoid. Ground the negative (-) battery wire to the motor housing.
6. Touch "hot" wire, from the positive battery terminal, to small terminal of the solenoid.
7. The motor should now be running if the solenoid is good. If not, make sure the motor will run directly from the battery.
8. To test the upper contacts use the same hookup except use the top terminals. (See Figure 2).

When the "hot" wire is touched to the small terminal the motor will stop operating.

The top terminals are normally closed; ie: connected, and the side terminals open, or not connected. When the solenoid operates, the top terminals are disconnected and the side terminals are connected.

Take care not to bring hot wires into contact with ground in order to prevent electrical arcing.

Solenoid Assemblies

278027 — 12 Volts
278028 — 24 Volts

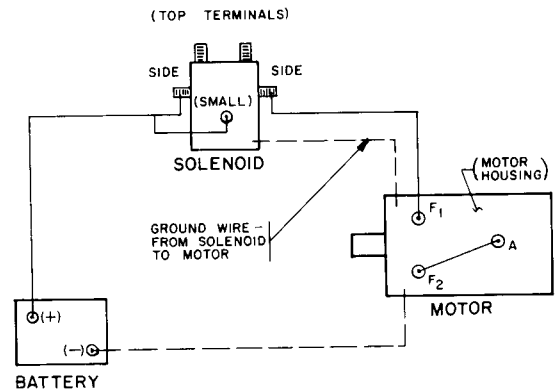
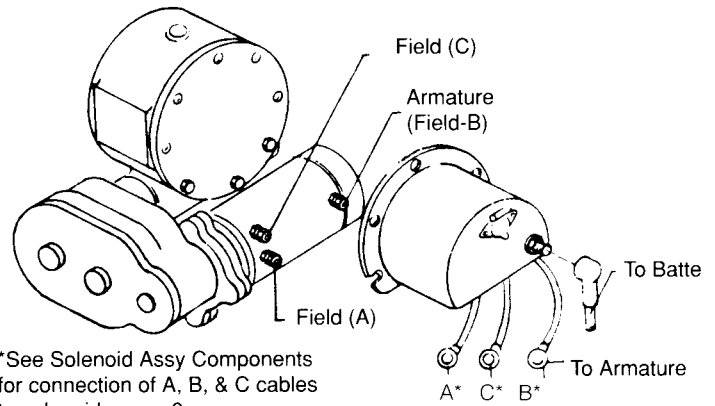

FIGURE -1

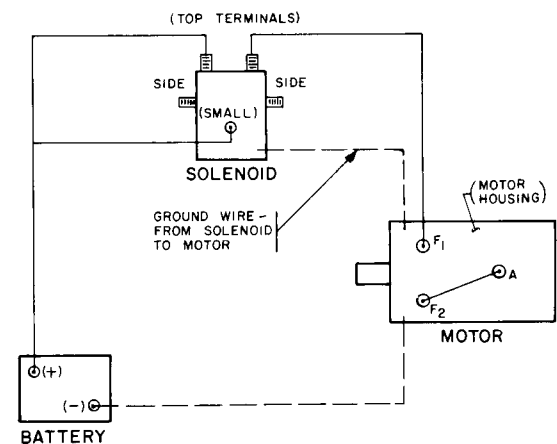

FIGURE -2

Test Procedure for Motor

The Ramsey Winch motor is a 4 pole, 4 coil series wound 12 volt or 24 volt DC motor.

The 4 pole, 4 coil feature provides high torque at low speeds.

To test the motor to determine if it is functioning properly, first securely fasten the motor to a bench or work surface so it will not jump or move around during test procedure (the starting torque of motor is high).

1. Connect a jumper wire (at least a number 6 wire) from F-1 to A motor terminals (See Figure 1).
2. Attach a wire (at least a number 6 wire) from positive (+) battery terminal to F-2 motor terminal. Ground negative (-) battery terminal to motor housing (See Figure 1). Motor should now run.

To reverse the direction of rotation:

1. Attach jumper wire from F-2 to (A) motor terminals (See Figure 2).
2. Attach wire from positive (+) battery terminal to F-1 motor terminal. Ground negative (-) battery terminal to motor housing (See Figure 2).

NOTE: Always attach battery wire solidly to motor terminals. Make and break the connection of the negative (-) battery terminal at the motor housing. This avoids burning the motor terminals. **CAUTION:** Do not run the motor for a long period of time in fashion mentioned above, because the motor could become damaged.

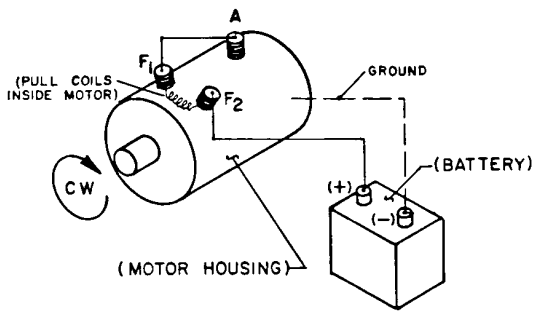

FIGURE -1
MOTOR - CLOCKWISE ROTATION

The motor running idle on the bench will draw 55 amperes and must run free and easy. If the ampere draw is more than 60 amps and the motor runs rough or has a strange sound, it should be replaced.

With the motor attached in place on a winch (less cable on drum) the ampere draw should be approximately 65 to 70 amps.

If after following the procedure outlined, the test on the winch significantly exceeds 70 amperes refer to your Owners Manual for troubleshooting suggestions on the mechanical portion of the winch.

See Figure 3 for the solenoids connection to the motor and battery.

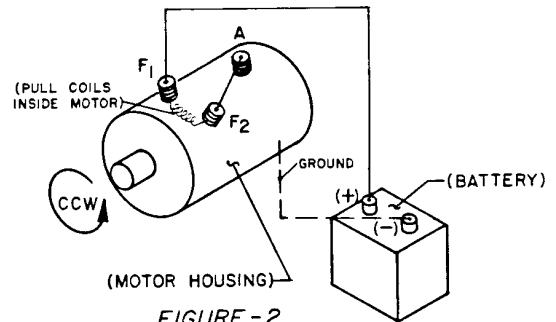
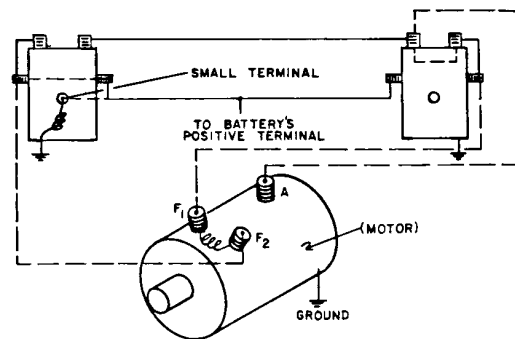

FIGURE -2
MOTOR - COUNTER CLOCKWISE ROTATION



SOLENOIDS TO MOTOR CONNECTIONS

THE DASHED LINES ARE CURRENT'S PATH IN FORWARD ROTATION. SOLID LINES ARE CURRENT'S PATH AT ALL TIMES.

NOTE: DIRECTION OF MOTOR ROTATION DEPENDS ON WHICH SMALL TERMINAL OF EITHER SOLENOID IS CONNECTED TO BATTERY'S POSITIVE TERMINAL

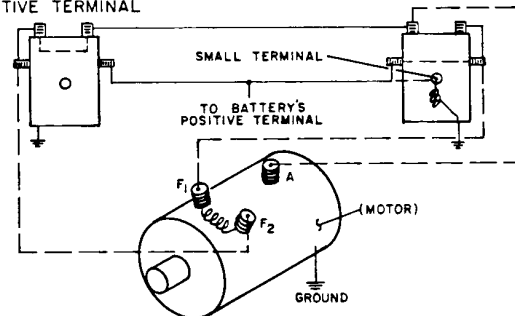

SOLENOIDS TO MOTOR CONNECTIONS

THE DASHED LINES ARE THE CURRENT'S PATH IN REVERSE ROTATION. SOLID LINES ARE CURRENT'S PATH AT ALL TIMES.

FIGURE - 3

Warranty Information

Ramsey Winches are designed and built to exacting specifications. Care and skill go into every winch we make. If the need should arise, warranty procedure is outlined on the back of your self-addressed postage paid warranty card. Please read and fill out the enclosed warranty card and send it to Ramsey Winch Company. If you have any problems with your winch, please follow instructions for prompt service on all warranty claims.

Limited Lifetime Warranty

Ramsey Winch offers a limited lifetime warranty for each new Ramsey consumer/RV winch against manufacturing defects in workmanship and materials on all mechanical components.

Warranty registration cards for each winch must be submitted at the time of purchase or within 30 days. Warranty will only be valid for the original purchaser of the winch and installed on the vehicles with which they were originally registered.

New cable assemblies are warranted against defects in workmanship and materials. No warranty applies after initial use.

All Ramsey mounting kits and other accessories carry a 1-year limited warranty against defects in materials & workmanship.

Chrome finish warranted for one year against manufacturing defects. Cracking, scratching or corrosion caused by winching not covered by warranty.

This warranty is void if winch is used in commercial/industrial applications other than front mount self recovery.

Electrical components consisting of motors, solenoids, wiring, wire connectors and associated parts carry a 1-yr. limited warranty. Battery isolators carry a 90-day limited warranty.

An optional extended 2-year limited warranty for all electrical components may be purchased.

The obligation under this Warranty, statutory or otherwise, is limited to the replacement or repair at the manufacturer's factory, or at a point designated by the manufacturer, of such part as shall appear to the manufacturer, upon inspection of such part, to have been defective in material or workmanship. This Warranty does not obligate Ramsey Winch Company to bear the cost of labor or transportation charges in connection with the replacement or repair of defective parts, nor shall it apply to a product upon which repairs or alterations have been made, unless authorized by the manufacturer, or for equipment misused, neglected or improperly installed.

IMPORTANT NOTICE: To the fullest extent permitted by applicable law, the following are hereby excluded and disclaimed: 1. All warranties of fitness for a particular purpose; 2. All warranties of merchantability; 3. All claims for consequential or incidental damages. There are no warranties that extend beyond the description that appears on the face hereof.

Some states do not allow the above exclusions or disclaimers in consumer transactions and as such this disclaimer/exclusion may not apply to your particular case.

To the extent such warranties of fitness for a particular purpose or merchantability are deemed to apply to this product, they exist for only so long as the express limited warranty elsewhere set forth is in existence.

Ramsey Winch Company makes no warranty in respect to accessories, same being subject to the warranties of their respective manufacturers.

Ramsey Winch Company, whose policy is one of continuous product improvement, reserves the right to improve any product through changes in design or materials as it may deem desirable without being obligated to incorporate such changes in products of previous manufacture.

If field service at the request of the buyer is rendered and the fault is found not to be with Ramsey Winch Company's product, the buyer shall pay the time and expense cost of the field representative. Bills for service, labor or other expenses which have been incurred by the buyer without express approval or authorization by Ramsey Winch Company will not be accepted.

This Warranty gives you specific legal rights and you may also have other legal rights which vary from state to state.



Ramsey Winch Company

Post Office Box 581510 • Tulsa, OK 74158-1510 • U.S.A. • Phone: (918) 438-2760 • FAX (918) 438-6688 • www.ramsey.com