

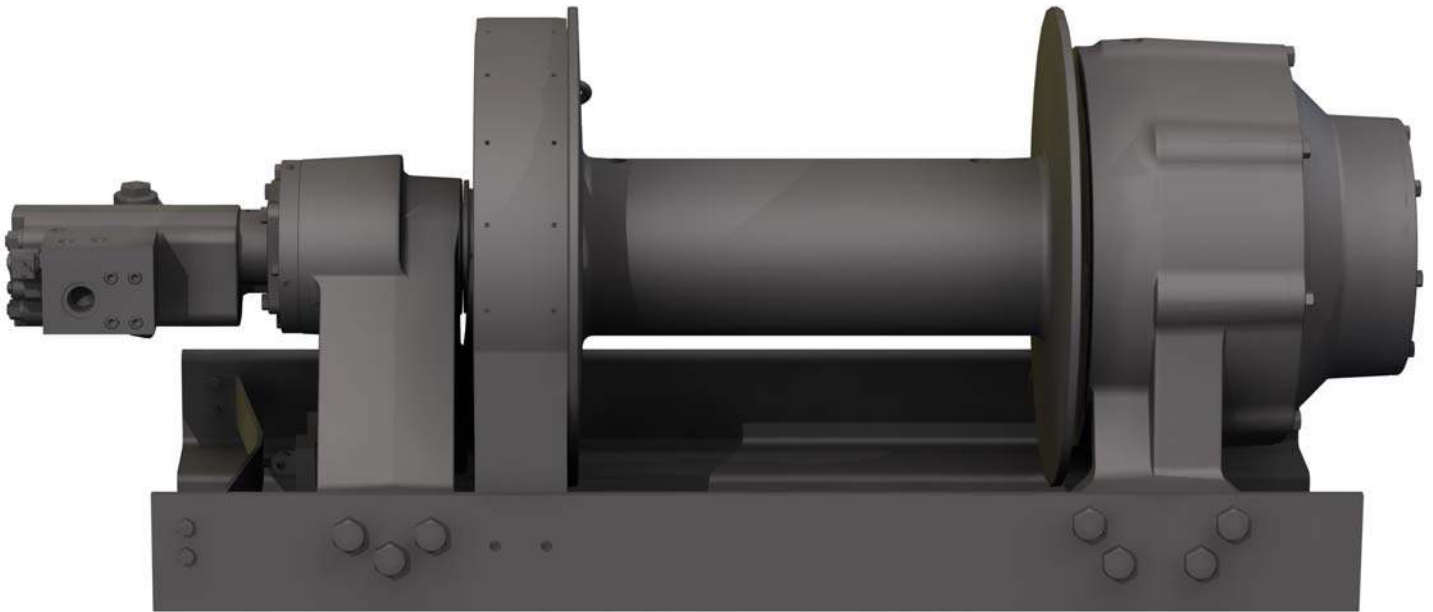

WILDCAT WINCH SERIES

**OPERATING, SERVICE AND
MAINTENANCE MANUAL**

By **RAMSEY**



WILDCAT SERIES 100,000 LB INDUSTRIAL WINCH



CAUTION: READ AND UNDERSTAND THIS MANUAL BEFORE INSTALLATION AND OPERATION OF WINCH. SEE WARNINGS!

TABLE OF CONTENTS

WARRANTY INFORMATION.....	1
SPECIFICATIONS.....	1
WARNINGS.....	1
HYDRAULIC SYSTEM REQUIREMENTS	2
CABLE INSTALLATION	3
CLUTCH OPERATION.....	4
WINCH OPERATION	4
MAINTENANCE	4
LUBRICATION TABLE	5
TROUBLE SHOOTING GUIDE.....	5
INSTRUCTIONS FOR DISASSEMBLY.....	6
CARRIER DISASSEMBLY AND ASSEMBLY	14
HOSE HOOKUP	21
PARTS DRAWING	22
PARTS LIST.....	23
AIR CYLINDER	24
DIMENSIONAL DRAWING	25
LIMITED WARRANTY.....	26

RAMSEY HYDRAULIC PLANETARY WINCH MODEL WILDCAT 100K

PLEASE READ THIS MANUAL CAREFULLY

This manual contains useful ideas in obtaining the most efficient operation from your Ramsey Winch, and safety procedures one needs to know before operating a Ramsey Winch. Do not operate this winch until you have carefully read and understand the "WARNINGS" and "OPERATION" sections of this manual.

WARRANTY INFORMATION

Ramsey Winches are designed and built to exacting specifications. Great care and skill go into every winch we make. If the need should arise, warranty procedure is outlined on the back of your self-addressed postage paid warranty card. Please read and fill out the enclosed warranty card and send it to Ramsey Winch Company. If you have any problems with your winch, please follow instructions for prompt service on all warranty claims. Refer to back page for limited warranty.

SPECIFICATIONS*

APPROXIMATE WEIGHT:		2200 LBS								
WORKING PRESSURE:		2850 PSI								
CABLE DIAMETER:		1.125 INCH								
MAX FLOW:		60 GPM								
LAYER OF CABLE	CABLE CAPACITY		LOW SPEED				HIGH SPEED			
			LINE PULL		LINE SPEED		LINE PULL		LINE SPEED	
	Ft	m	Lb	Kg	fpm	mpm	Lb	Kg	fpm	mpm
1	50	15	100000	45350	23	6.9	40000	18140	53	16.1
2	110	33	81800	37100	27	8.2	32700	14830	64	19.4
3	180	54	69200	31380	32	9.7	27600	12510	75	22.8
4	265	80	60000	27210	36	10.9	24000	10880	85	25.8
5	360	109	52900	23990	41	12.4	21100	9570	96	29.1
6	465	141	47300	21450	46	13.9	18900	8570	107	32.5
* These specifications are based on recommended wire rope of 1.125" Extra Improved Plow Steel Cable and a 9.0 cu. in. / Rev. motor.										

NOTE: The rated line pulls shown are for the winch only. Consult the wire rope manufacturer for wire rope ratings.

WARNINGS:

CLUTCH MUST BE FULLY ENGAGED BEFORE STARTING THE WINCHING OPERATION.

DO NOT START WINCH MOTOR BEFORE ENGAGING CLUTCH.

DO NOT DISENGAGE CLUTCH UNDER LOAD.

STAY OUT FROM UNDER AND AWAY FROM RAISED LOADS.

STAND CLEAR OF CABLE WHILE PULLING. DO NOT TRY TO GUIDE CABLE.

DO NOT EXCEED MAXIMUM LINE PULL RATINGS SHOWN IN TABLE.

DO NOT USE WINCH TO LIFT, SUPPORT, OR OTHERWISE TRANSPORT PEOPLE.

A MINIMUM OF 5 WRAPS OF CABLE AROUND THE DRUM BARREL IS NECESSARY TO HOLD THE LOAD.

CABLE ANCHOR IS NOT DESIGNED TO HOLD LOAD.

BAND BRAKE IS NOT TO BE USED TO HOLD LOAD.

HYDRAULIC SYSTEM REQUIREMENTS

Refer to the performance charts, below, to properly match your hydraulic system to winch performance. The charts consist of:

(1) Line pull (lb.) first layer vs. working pressure (PSI) and (2) line speed, first layer (FPM) vs. gallons per minute (GPM). Performance based on a motor displacement of 9.0 cubic inches/rev with 60 GPM maximum flow rate. Motor has (2) 1"-12 SAE straight thread o-ring ports.

Note: A motor spool (open center) directional control valve is required for brake operation.

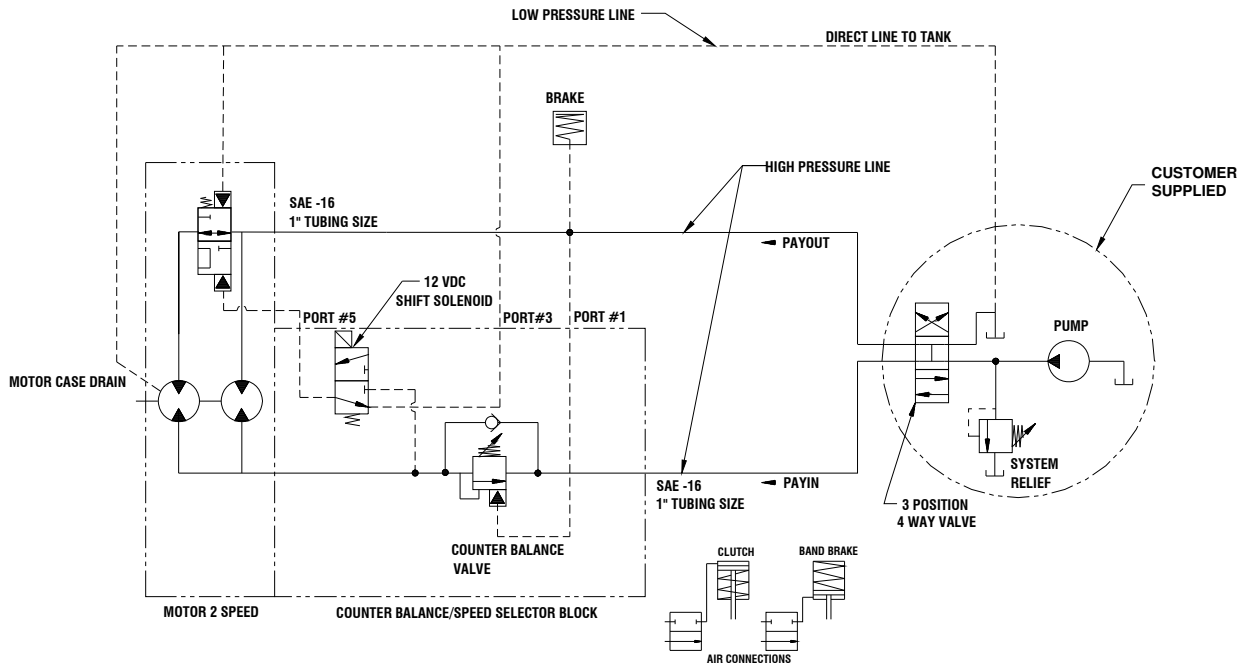

PERFORMANCE CHARTS

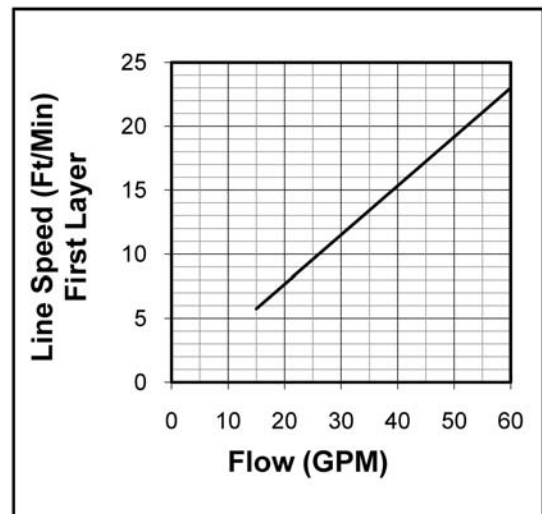
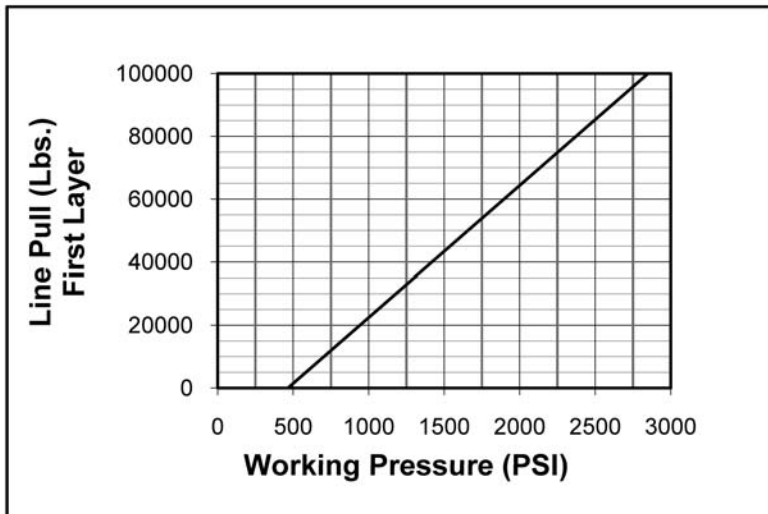

BASED ON 9.0 CU IN/REV MOTOR

CABLE INSTALLATION

1. Unwind cable by rolling it out along the ground to prevent kinking. Securely wrap end of wire rope, opposite hook, with plastic or similar tape to prevent fraying.
2. Place taped end of cable into hole on drum flange and bend into the track on drum flange. Secure using supplied u-bolt #73 and (2) nuts.
3. Carefully run the winch in the "reel-in" direction. Keeping tension on end of cable, spool all the cable onto the cable drum, taking care to form neatly wrapped layers.
4. After installing cable, band brake is used to prevent bird nesting while pulling out cable, when clutch is disengaged.

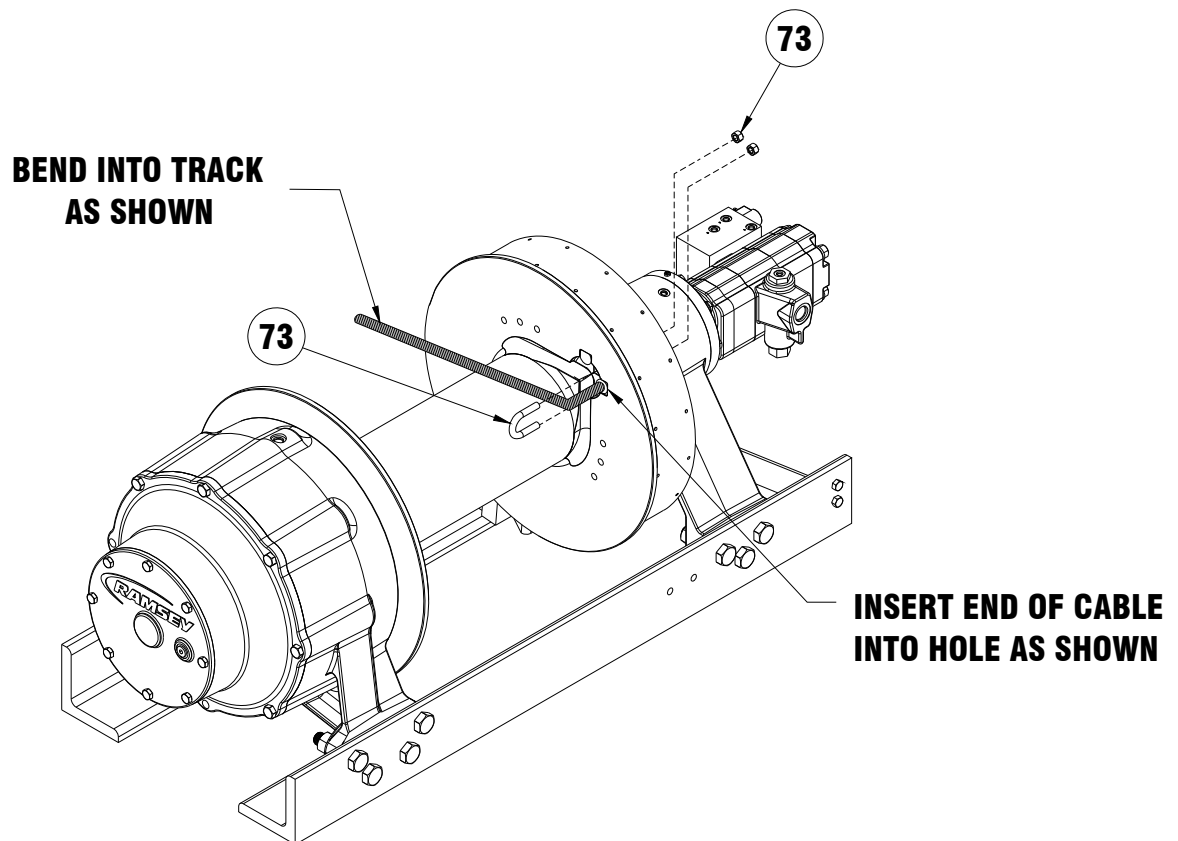

CLUTCH OPERATION

WARNING: CLUTCH MUST BE FULLY ENGAGED BEFORE STARTING THE WINCHING OPERATION.

To engage clutch:

1. Move clutch control to engage the clutch.
2. Run the motor in the cable out direction until the drum begins to turn.

WARNING: DO NOT DISENGAGE CLUTCH UNDER LOAD.

To disengage clutch:

1. Run the winch in the "cable out" direction until the load is off the cable.
2. Move the clutch control to disengage the clutch. The cable may now be spooled off.

WINCH OPERATION

The best way to get acquainted with how your winch operates is to make test runs before you use it. Plan your test in advance. Remember, you hear your winch, as well as see it operate; learn to recognize the sounds of a light steady pull, a heavy pull, and sounds caused by load jerking or shifting. Gain confidence in operating your winch and its use will become second nature with you.

The uneven spooling of cable while pulling a load is not a problem, unless there is a cable pileup on one end of drum. If this happens reverse the winch to relieve the load and move your anchor point further to the center of the vehicle. After the job is done you can unspool and rewind for a neat lay of the cable.

MAINTENANCE

Adhering to the following maintenance schedule will keep your winch in top condition and performing as it should with a minimum of repair.

A. WEEKLY

1. Check the oil level and maintain it to the oil level plug. If oil is leaking out, determine location and repair.
2. Check the pressure relief plug on the gear housing cover and the brake housing cover. Be sure they are not plugged.
3. Lubricate cable with light oil.
4. Lubricate drum bushings with grease. It is necessary to remove cable to expose the grease zerks on drum. Use high quality lithium grease for best results.
5. Apply a high quality lithium grease to clutch spline. Apply band brake to control drum. Declutch drum and apply grease to spline between clutch and drum.

B. MONTHLY

1. Check the winch mounting bolts. If any are missing, replace them and securely tighten any that are loose. Use grade 8 or better bolts.
2. Inspect the cable. If the cable has become frayed with broken strands, replace immediately.

C. ANNUALLY

1. Drain the oil from the winch annually or more often if winch is used frequently.
2. Refill the winch to the oil level plug with all purpose GL-5 oil, (see page 5) for gear lube compatible with your climate.
3. Inspect winch for damage and wear.

LUBRICATION TABLE

Lubricant Description*	Temp Range F(C)		
	Min Ambient & Operating	Max Ambient	Max Operating
80W140 Synthetic	-25 (-32)	125 (52)	225 (107)
75W90 Synthetic	-40 (-40)	115 (46)	215 (102)
80W90 Conventional	-20 (-29)	100 (38)	180 (82)
85W140 Conventional	20 (6)	120 (50)	200 (93)
*Use API GL-5 or EP lubricants.			

TROUBLE SHOOTING GUIDE

CONDITIONS	POSSIBLE CAUSE	CORRECTION
OIL LEAKS FROM WINCH	<ol style="list-style-type: none"> 1. Seals damaged or worn. 2. Too much oil. 3. Damaged o-rings. 4. Case drain not connected. 	<ol style="list-style-type: none"> 1. Replace seal. 2. Drain excess oil. Refer to page 6. 3. Replace o-rings. 4. Connect case drain.
WINCH RUNS TOO SLOW	<ol style="list-style-type: none"> 1. Low flow rate. 2. Hydraulic motor worn out. 	<ol style="list-style-type: none"> 1. Check flow rate. Refer to HYDRAULIC SYSTEMS performance chart on page 2. 2. Replace motor.
CABLE DRUM WILL NOT FREESPOOL	<ol style="list-style-type: none"> 1. Clutch not disengaged. 	<ol style="list-style-type: none"> 1. Check operation. Refer to Clutch Operation on page 4.
BRAKE WILL NOT HOLD	<ol style="list-style-type: none"> 1. Incorrect directional control valve. (cylinder spool, closed center). 2. Excessive hydraulic system back pressure. 3. Sprag clutch worn out. 	<ol style="list-style-type: none"> 1. Use only a motor spool (open center) directional control valve. 2. Reduce system back pressure to less than 100 psi. 3. Replace sprag clutch mechanism.
BRAKE WILL NOT RELEASE	<ol style="list-style-type: none"> 1. Brake line disconnected or blocked 	<ol style="list-style-type: none"> 1. Repair brake line.
WINCH WILL NOT OPERATE AT HIGH SPEED	<ol style="list-style-type: none"> 1. Shift solenoid not working. 	<ol style="list-style-type: none"> 1. Verify shift spool is energized.
WINCH OPERATES ERRATICALLY ON INHAUL	<ol style="list-style-type: none"> 1. Sprag hub is reversed. 	<ol style="list-style-type: none"> 1. Install sprag hub correctly.

INSTRUCTIONS FOR DISASSEMBLY

1. Remove wire rope from drum.
2. Drain oil from winch by removing (2) plugs #63, removing the lower plug first.
3. When replacing lubricant, use 496 oz of applicable lube for your climate from table on page 5, adding 16 oz at #52 and the remaining at #64.

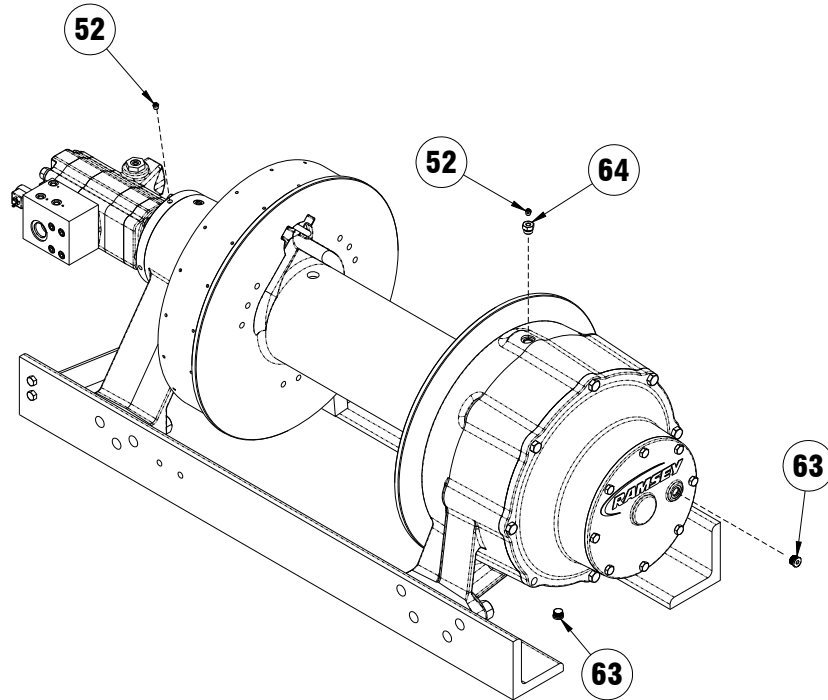

4. Remove (2) nuts #408b from air cylinder #408a. Air cylinder may now be removed. If needed, mounting bracket #401 may be removed by removing pin #404 from pin #405 and then sliding pin out of mounting bracket. Brake band #6 may be expanded over drum flange to barrel for easiest removal.

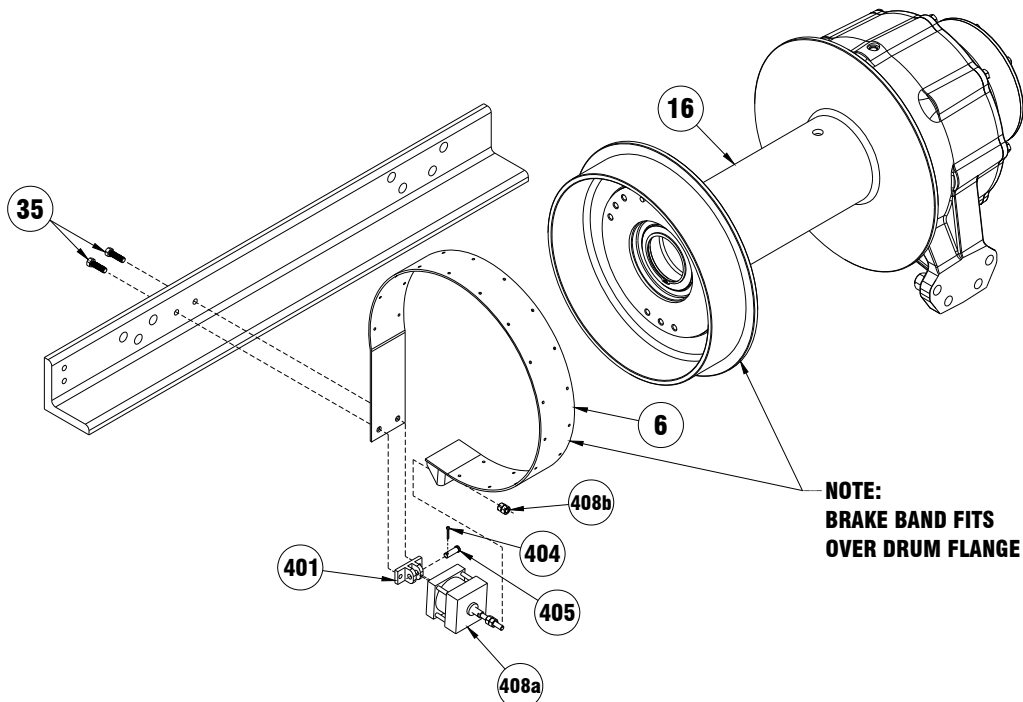

5. Remove motor #53 from winch by first disconnecting hydraulic lines (see page 17), solenoid wires, and then remove (4) bolts #36. O-ring #55 may now be removed.
6. Remove brake cover #50 by removing (4) bolts #35. **The cover is spring loaded, use care when removing.** Remove o-ring #54 then springs #69 may be removed; residual oil may be present in the brake housing.
7. Remove piston #13 including o-rings and backup rings #56, #57, #58, and #59 by using a momentary puff of compressed air into the brake port located on top of the end bearing. Capture the piston by placing a shop rag over the opening prior to using air. Capture the piston by placing a shop rag over the opening prior to using air.
8. Remove the sprag brake hub assembly #5, (7) stator plates #14, (6) disc brakes #15, and the spacer #25. The sprag brake hub assembly #5 is not a serviceable part, if damaged a replacement assembly should be ordered.

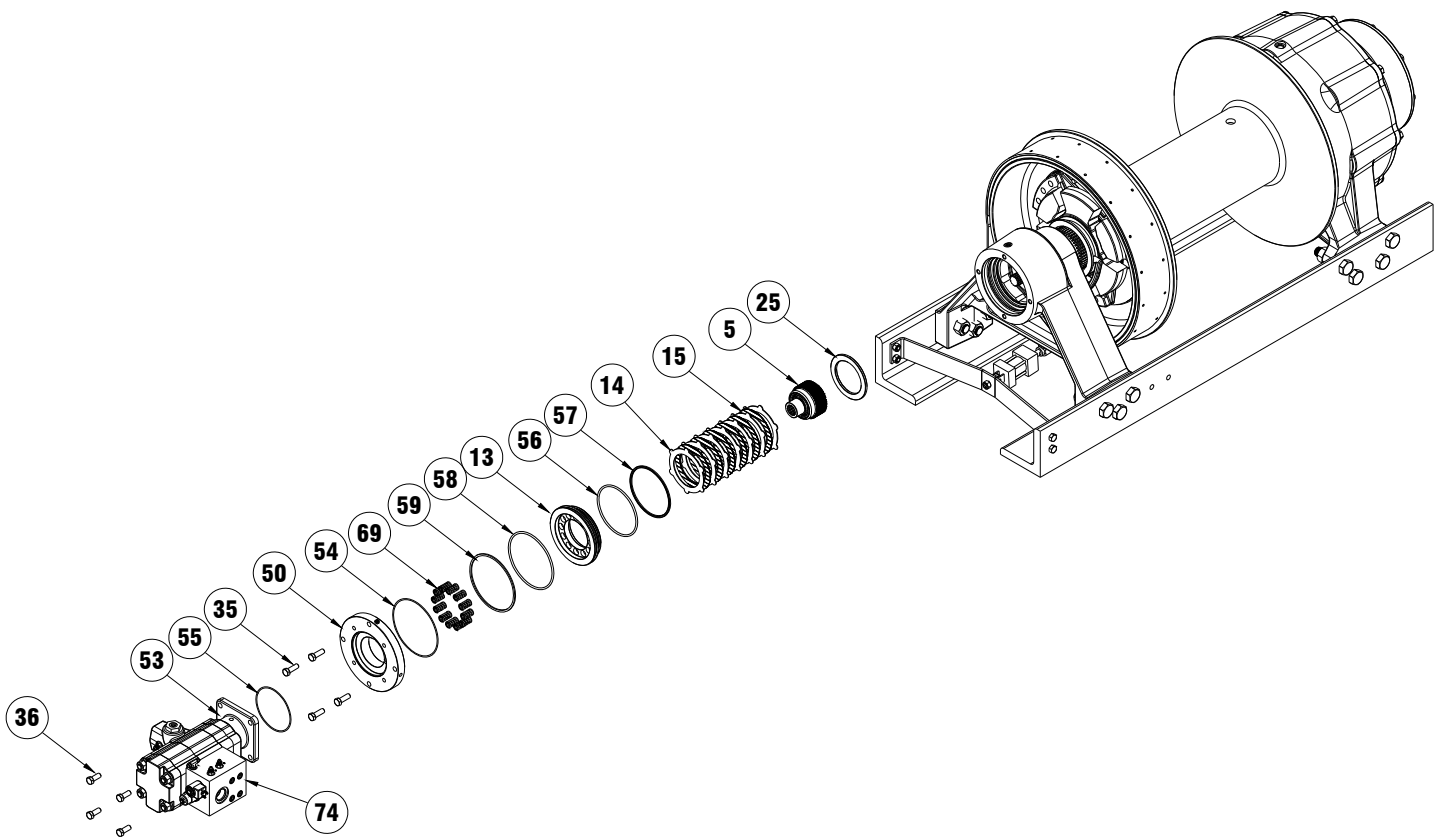

9. Remove (8) cover bolts #33, cover #12, and o-ring #60.
10. Remove snap ring #67, and sun gear #18.
11. The planetary carrier assembly #2 may now be removed along with (2) spacers #24.
12. Remove second snap ring #67 and intermediate sun gear #17.
13. Planetary carrier assembly #4 may now be removed.

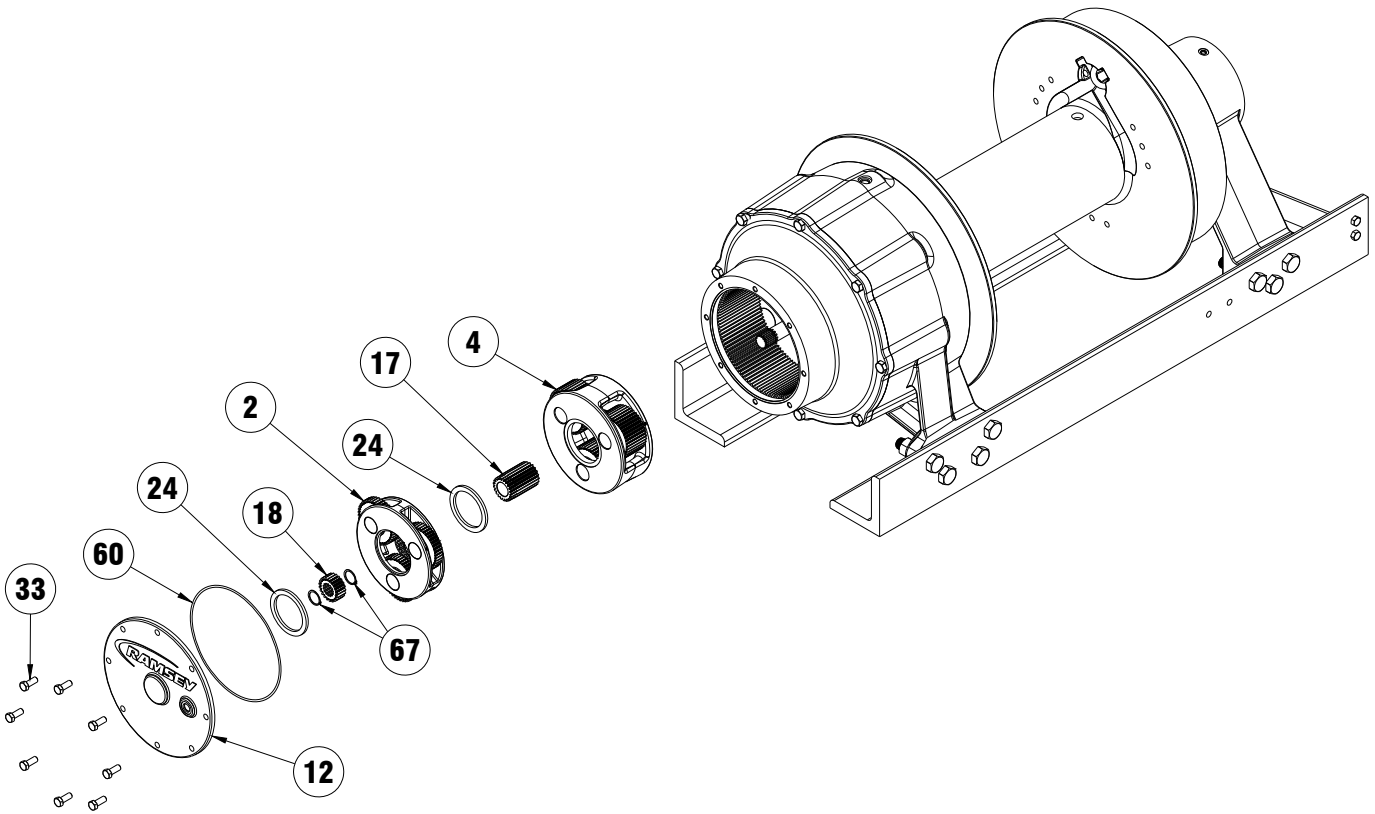

14. Using a nylon strap, support ring gear #22 from a hoist or boom, **this ring gear is heavy**.
Remove (8) bolts #37 leaving the top most bolt for last. Remove the final bolt while supporting ring gear. Set ring gear aside. Remove the o-ring #61.
15. Remove spacer #28 and the output sun gear #19.

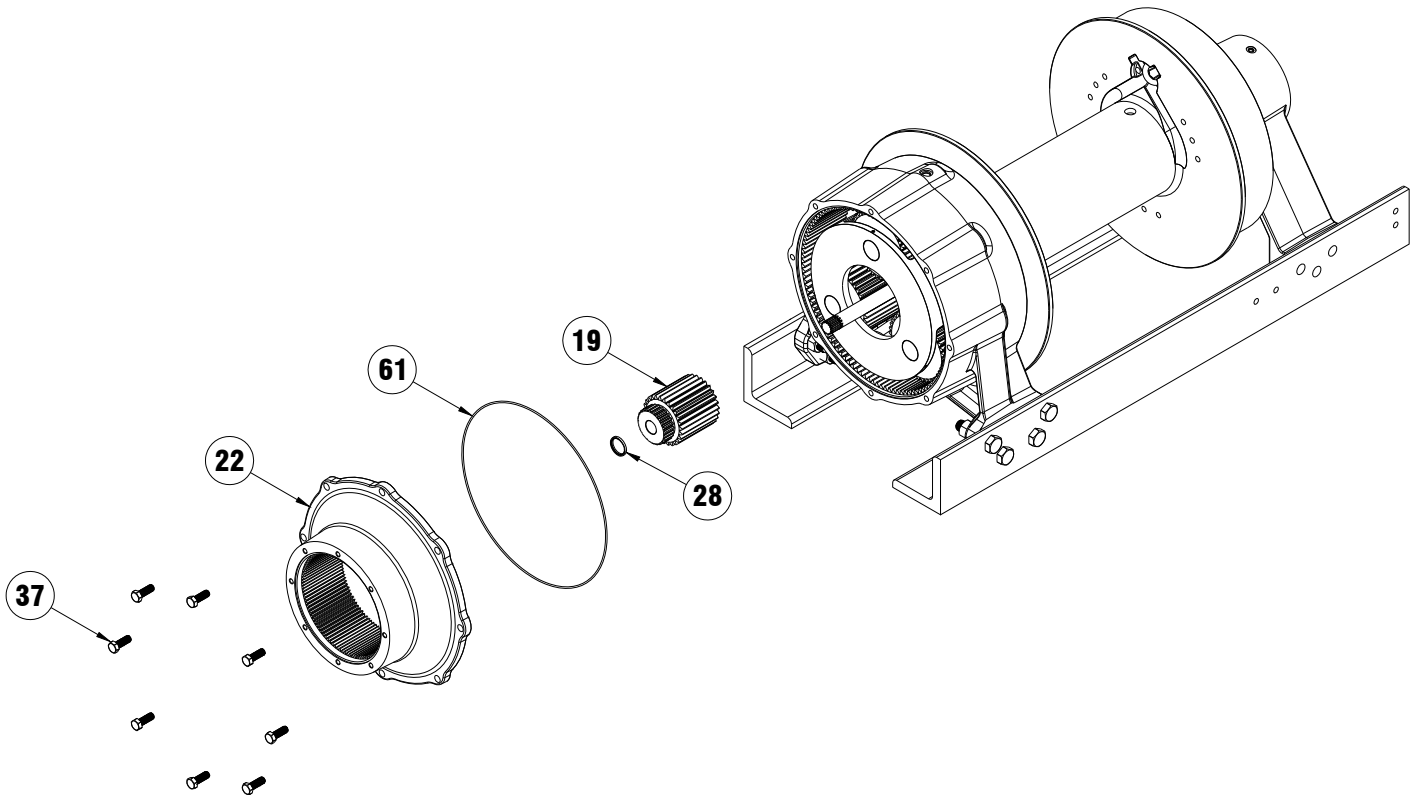

16. Remove the clutch cylinder #407 by removing the (2) cotter keys #404 and (2) pins #406 from either end of the air cylinder #407.
17. The clutch cylinder support bracket #9 can be removed by removing the four bolts #35 and nuts #41 attaching it to the mounting angles.
18. Remove the clutch yoke #29 by removing center pivot bolt #34 and nut #41.

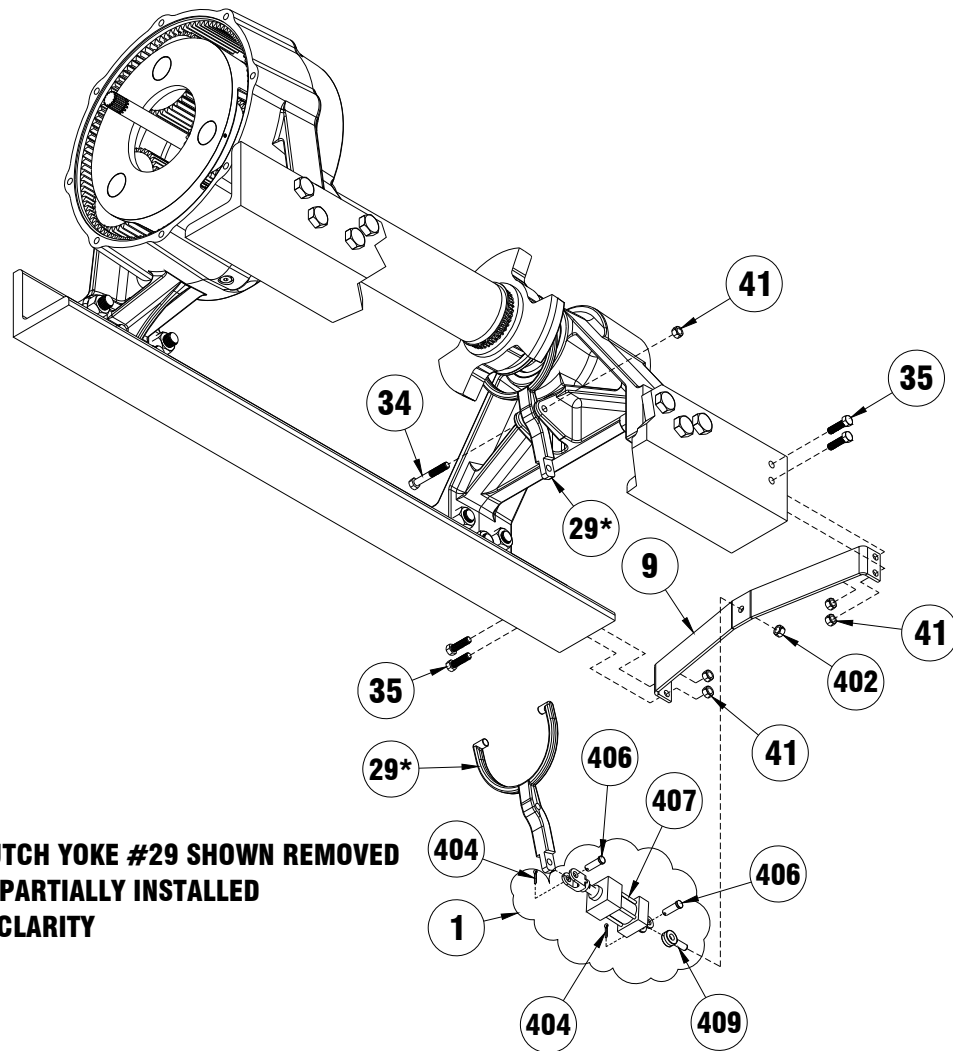

19. By removing snap ring #67 and ball bearing #30, the input shaft #23 may be removed.
20. To remove the motor end bearing #20, support drum #16 with a nylon strap or chain and hoist. Lift on the drum to tension the strap. Remove (6) bolts #39 and (6) nuts #42 attaching the end bearing to the mounting angles #7 and #8. The motor end bearing #20 will be supported on the output shaft end and may be slid off using a nylon strap and hoist to lift it.

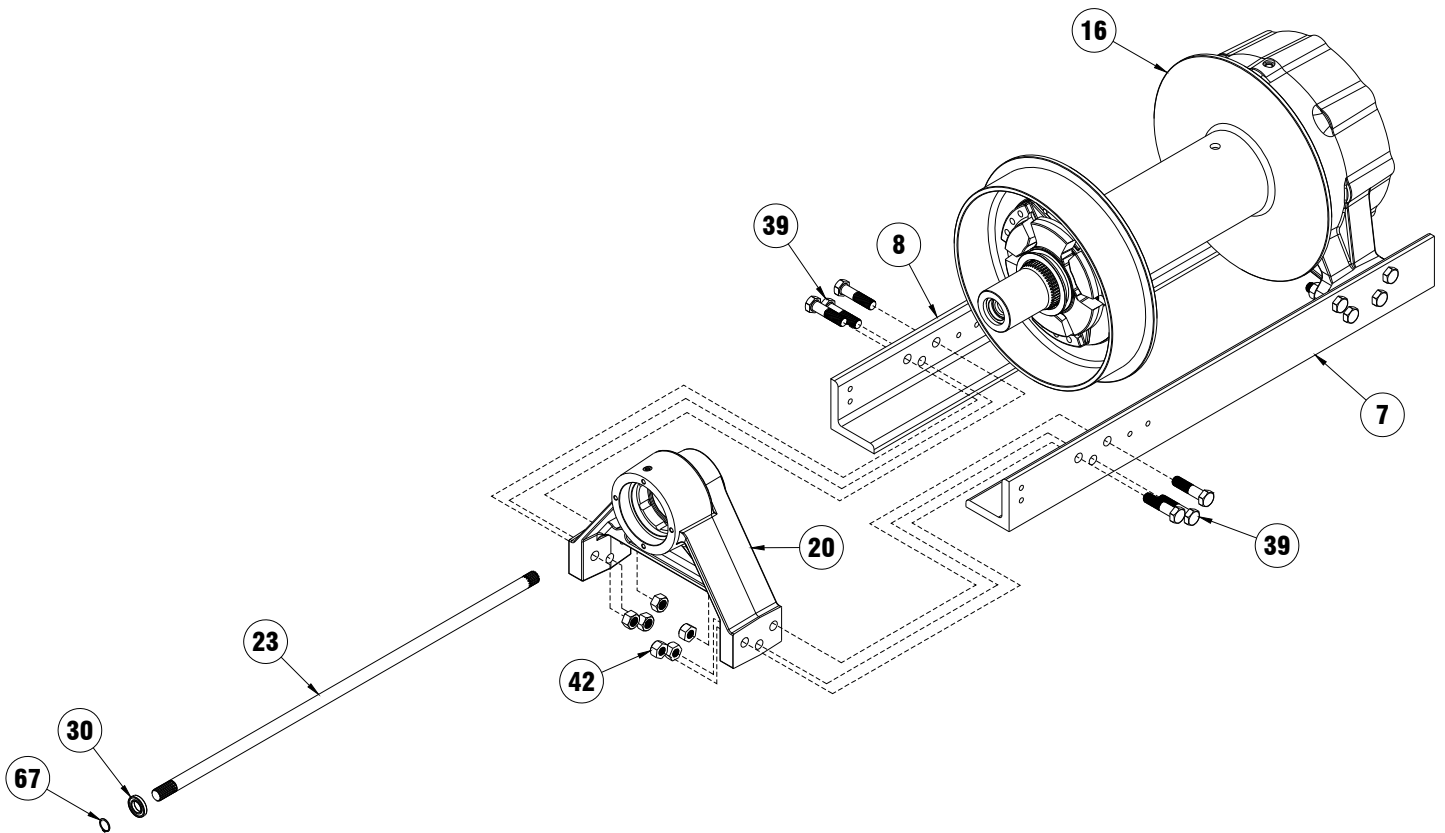

21. While continuing to support the drum #16, remove the clutch #10, snap ring #68 and spacer #26.
22. The output carrier assembly #23 may be slid from the drum assembly.
23. If required, spacer #27 can be removed from output carrier assembly.
24. The drum #14 is now supported only by the nylon strap and maybe removed as needed.
25. Remove drum driver #11 by removing (9) bolts #38.
26. The (2) bushings #31 may be pressed from the drum if replacement is necessary.

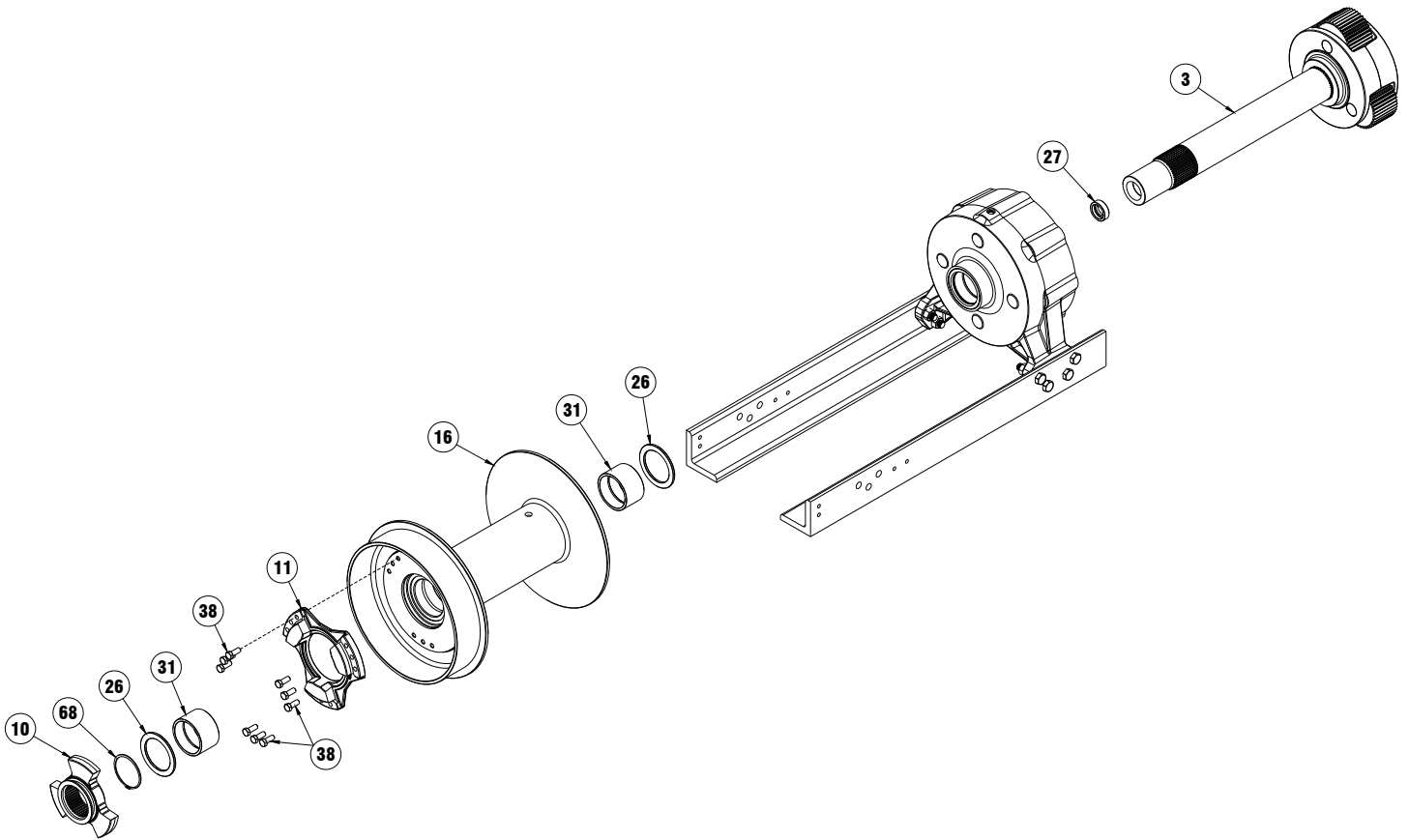

27. To remove gear end bearing #21, from mounting angles #7 and #8, first remove (4) bolts #40 and (4) nuts #42 from each angle. Shaft oil seal #66 and end bearing bushing # 31 can be removed and replaced at this time, if necessary.

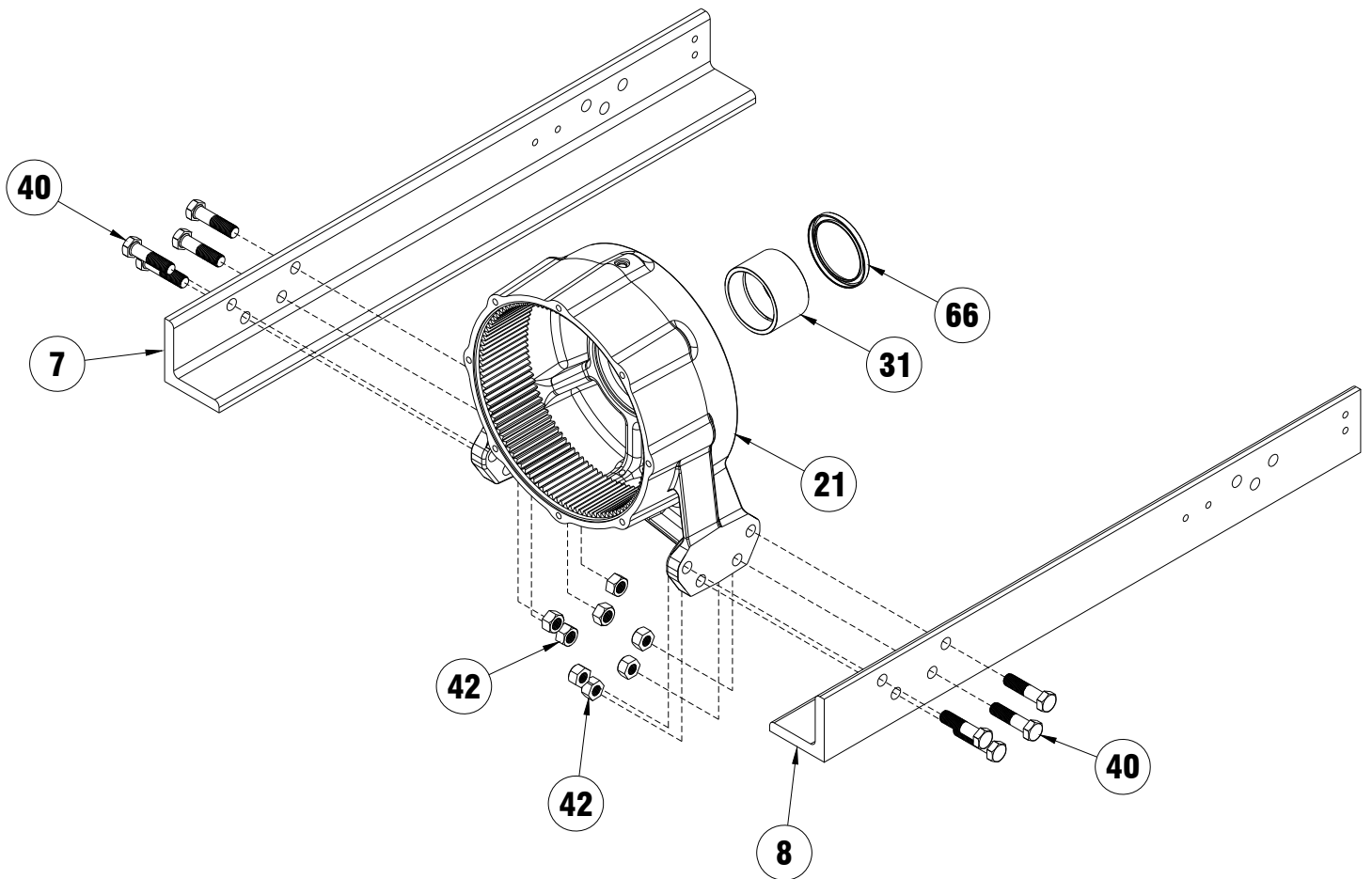

DISASSEMBLY OF INPUT CARRIER

Carrier assemblies may be purchased as a complete assembly (see pg. 23) or parts may be purchased individually (see parts list below). If purchasing individual parts, it will be necessary to disassemble the input gear carrier as outlined below.

1. Carefully drive roll pin #105 into carrier pin #104 so that it is captured within carrier pin #104 but not touching the opposite side of the input carrier #101.
2. Tap carrier pin #104 to remove it from the input carrier #101.
3. Place a plastic pail in a position to catch bearings #103 and washers #106. Then slide the gear #102 from the carrier #101.
4. Remove the roll pin #105 from the carrier pin #104.
5. Repeat this process for the two remaining gears in the carrier.

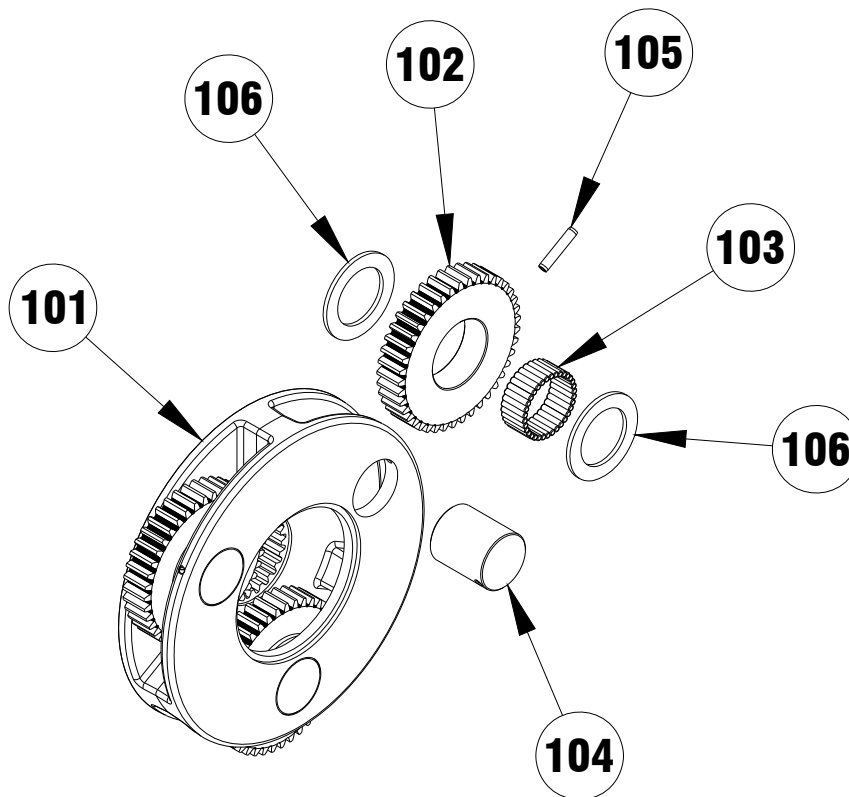

ITEM	QTY	PART NO	DESCRIPTION
101	1	317018	INPUT CARRIER
102	3	334206	PLANET GEAR
103	102	402135	NEEDLE BEARING
104	3	470111	PLANETARY PIN
105	3	470123	ROLL PIN
106	6	518067	THRUST WASHER

ASSEMBLY OF INPUT CARRIER

Note: Item Numbers refer to Carrier parts list on page 14

1. Place output carrier #101 on flat clean surface.
2. A tool the width of the gear #102 and the diameter of the carrier pin #104 is helpful to install needle bearings #103.
3. Place the output gear #102 on a flat thin clean metal plate; metal plate should not be thicker than thrust washer #106 and should be able to slide into gear pocket of output carrier #101. Grease the inside of gear #102 and insert the greased tool described above into gear #102.
4. Place the row of needle bearings #103 into gear #102 carefully sliding them down the gap between the tool and the gear so they stand vertically.
5. With tool remaining in place slide the gear #102 (resting on the thin plate) into position in the output carrier #101.
6. Place thrust washer #106 on top of gear #102. Insert carrier pin #104 into carrier #101
7. Turn output carrier #101 on its side so that the gear #102 is on top. Remove the thin plate. Remove tool by pushing carrier pin #104 into output carrier #101 until planet pin is at least half way past the row of bearings #103. The tool may now be removed completely.
8. Insert a thrust washer between gear #102 and output carrier #101. Completely insert carrier pin #104 into carrier #101 using care to align the roll pin hole in carrier pin #104 with the roll pin hole in the output carrier #101.
9. Drive roll pin #105 into output carrier #101 until roll pin #105 is ¼" past flush with surface of the output carrier #101.
10. Repeat this process to install the two remaining gears into the output carrier.

DISASSEMBLY OF INTERMEDIATE CARRIER

Carrier assemblies may be purchased as a complete assembly (see pg. 23) or parts may be purchased individually (see parts list below). If purchasing individual parts, it will be necessary to disassemble the intermediate gear carrier as outlined below.

1. Carefully drive roll pin #205 into carrier pin #206 so that it is captured within carrier pin #206 but not touching the opposite side of the intermediate carrier #201.
2. Tap carrier pin #206 to remove it from the intermediate carrier #201.
3. Place a plastic pail in a position to catch bearings #204, spacers #203, and washers #207. Then slide the gear #202 from the carrier #201.
4. Remove the roll pin #205 from the carrier pin #206.
5. Repeat this process for the two remaining gears in the carrier.

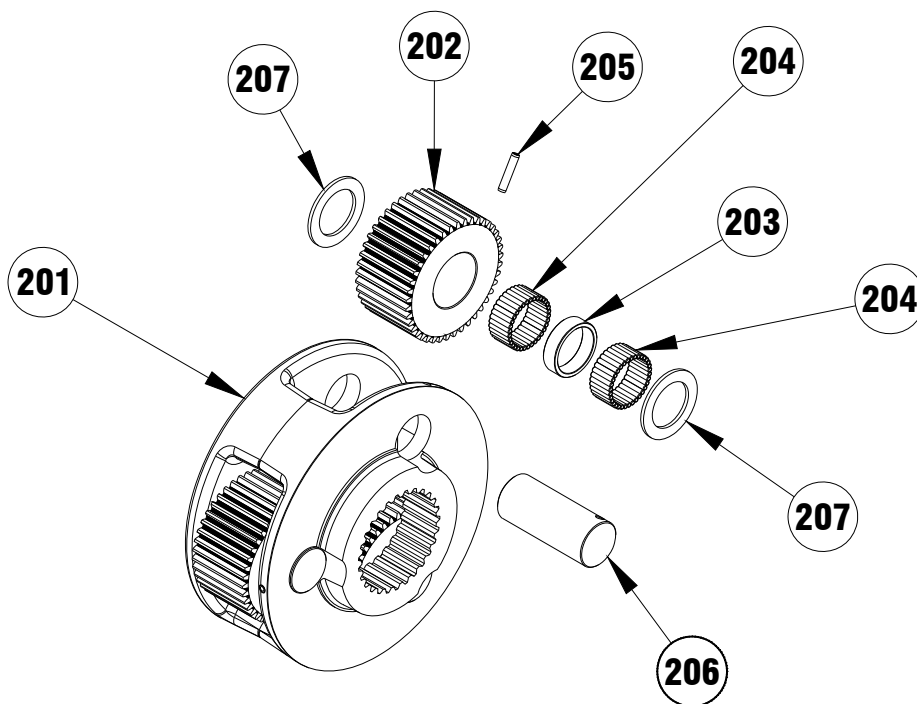

ITEM	QTY	PART NO	DESCRIPTION
201	1	317028	INTERMEDIATE CARRIER
202	3	334204	PLANET GEAR
203	3	362307	BEARING SPACER
204	204	402136	NEEDLE BEARING
205	3	470036	ROLL PIN
206	3	470113	PLANETARY PIN
207	6	518067	THRUST WASHER

ASSEMBLY OF INTERMEDIATE CARRIER

Note: Item Numbers refer to Carrier parts list on page 16

1. Place carrier #201 on flat clean surface.
2. A tool the width of the gear #202 and the diameter of the carrier pin #206 is helpful to install needle bearings #204.
3. Place the planet gear #202 on a flat thin clean metal plate. Metal plate should not be thicker than thrust washer #207 and should be able to slide into gear pocket of carrier #201. Grease the inside of gear #202 and insert the greased tool described above into gear #202.
4. Place one row of needle bearings #204 into gear #202 carefully sliding them down the gap between the tool and the gear so they stand vertically.
5. Install spacer #203, and the next row of needle bearings #204 as detailed in step 4 above.
6. With tool remaining in place slide the gear #202 (resting on the thin plate) into position in the carrier #201.
7. Place thrust washer #207 on top of gear #202. Insert carrier pin #206 into carrier #201
8. Turn carrier #201 on its side so that the gear #202 is on top. Remove the thin plate. Remove tool by pushing carrier pin #206 into carrier #201 until planet pin is at least half way past the last row of bearings #204. The tool may now be removed completely.
9. Insert a thrust washer #207 between gear #202 and carrier #201. Completely insert carrier pin #206 into carrier #201 using care to align the roll pin hole in carrier pin #206 with the roll pin hole in the carrier #201.
10. Drive roll pin #205 into carrier #201 until roll pin #205 is $\frac{1}{4}$ " past flush with surface of the carrier #201.
11. Repeat this process to install the two remaining gears into the output carrier.

DISASSEMBLY OF OUTPUT CARRIER

Carrier assemblies may be purchased as a complete assembly (see pg. 23) or parts may be purchased individually (see below). If purchasing individual parts, it will be necessary to disassemble the gear carrier as outlined below.

1. Carefully drive roll pin #305 into carrier pin #306 so that it is captured within carrier pin #306 but not touching the opposite side of the output carrier #301.
2. Tap carrier pin #306 to remove it from the output carrier #301.
3. Slide the planet gear #302 and the (2) thrust washers #308 from the carrier assembly #301. Bearings #304 may then be removed.
4. Remove the roll pin #305 from the carrier pin #306.
5. Repeat this process for the two remaining gears in the carrier.

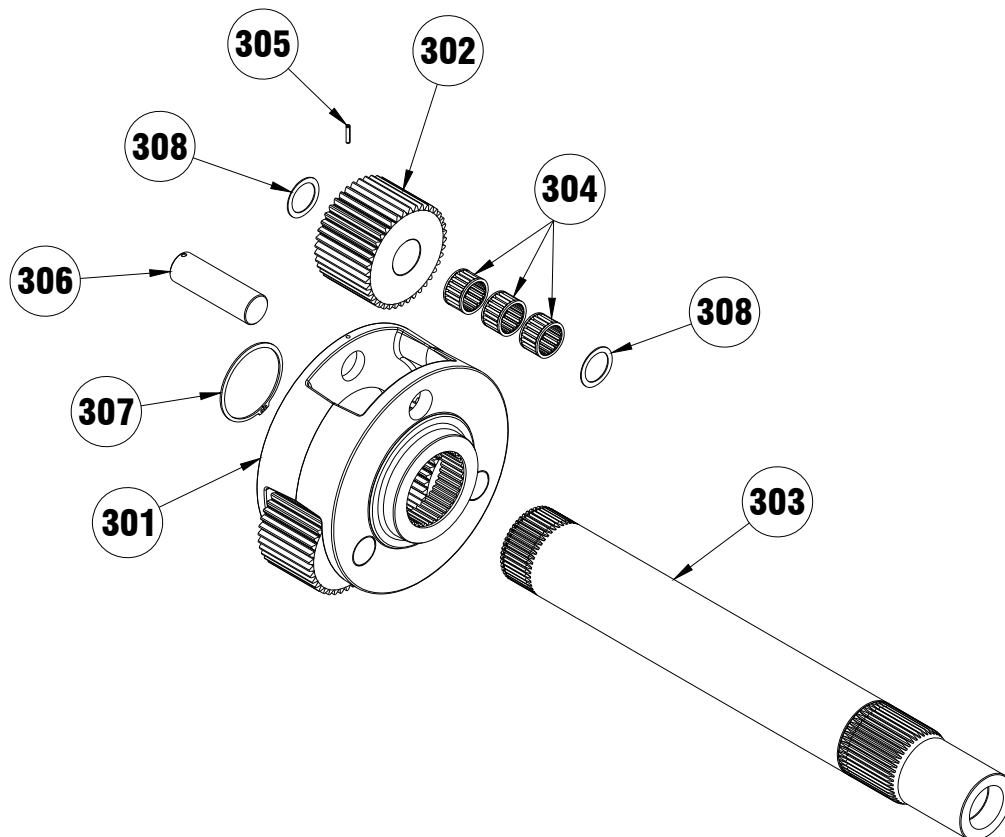

ITEM	QTY	PART NO	DESCRIPTION
301	1	317027	OUTPUT CARRIER
302	3	334229	PLANET GEAR
303	1	357538	OUTPUT SHAFT
304	9	402144	NEEDLE BEARING
305	3	470036	ROLL PIN
306	3	470131	PLANETARY PIN
307	1	490069	RETAINER RING
308	6	518076	THRUST WASHER

ASSEMBLY OF OUTPUT CARRIER

Note: Item Numbers refer to Carrier parts list on page 18

1. Place carrier #301 on flat clean surface.
2. Place the gear #302 on a flat thin clean metal plate. Slide the bearings #304 into gear #302.
3. Place thrust washer #308 on top of gear #302. Partially insert planet pin #306 into carrier #301.
4. Insert a thrust washer between gear #302 and carrier #301. Completely insert planet pin #306 into carrier #301 using care to align the roll pin hole in planet pin #306 with the roll pin hole in the carrier #301.
5. Drive roll pin #305 into carrier #301 until roll pin #305 is $\frac{1}{4}$ " past flush with surface of the carrier #301.
6. Repeat this process to install the two remaining gears into the carrier.

NOTES

HOSE HOOKUP

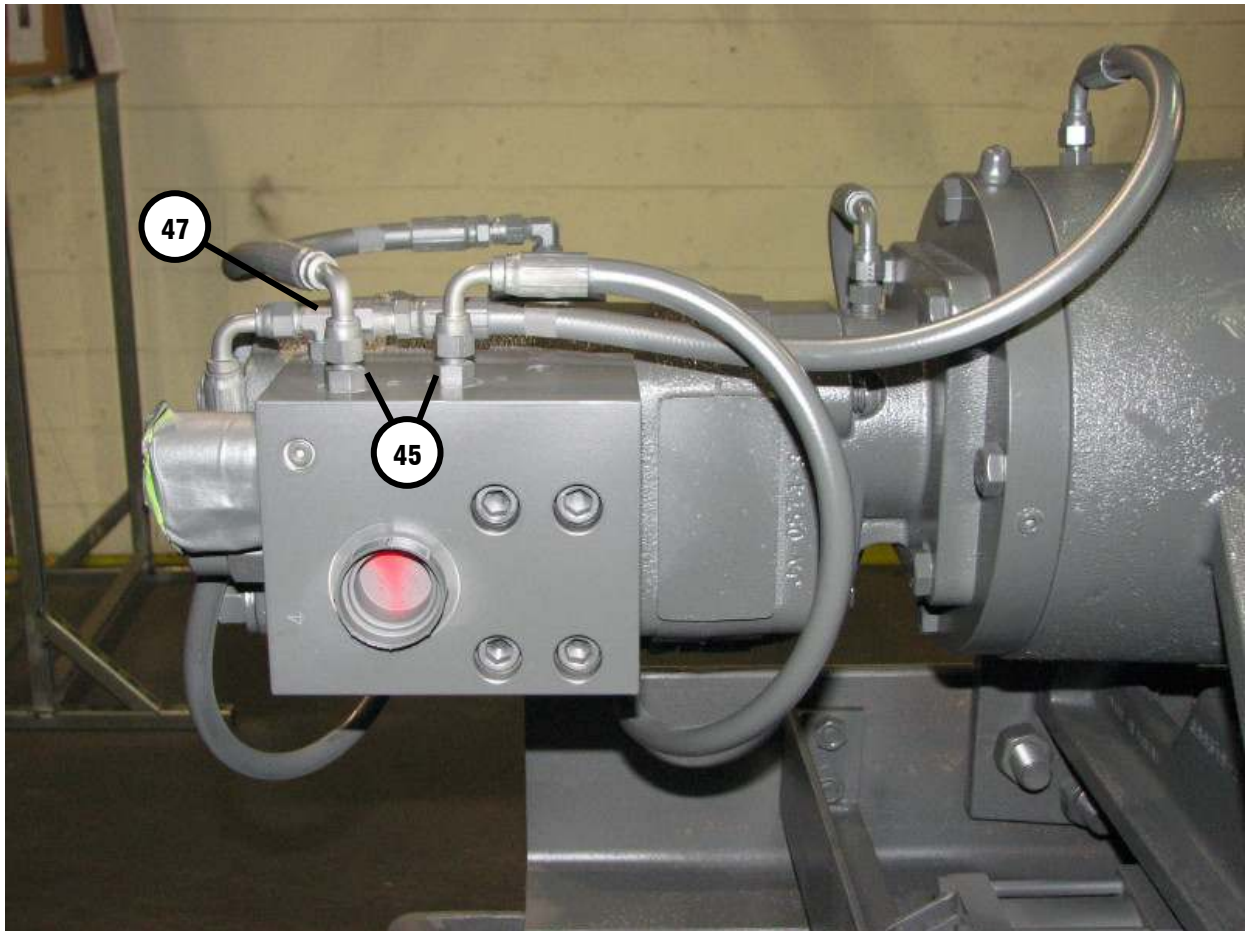
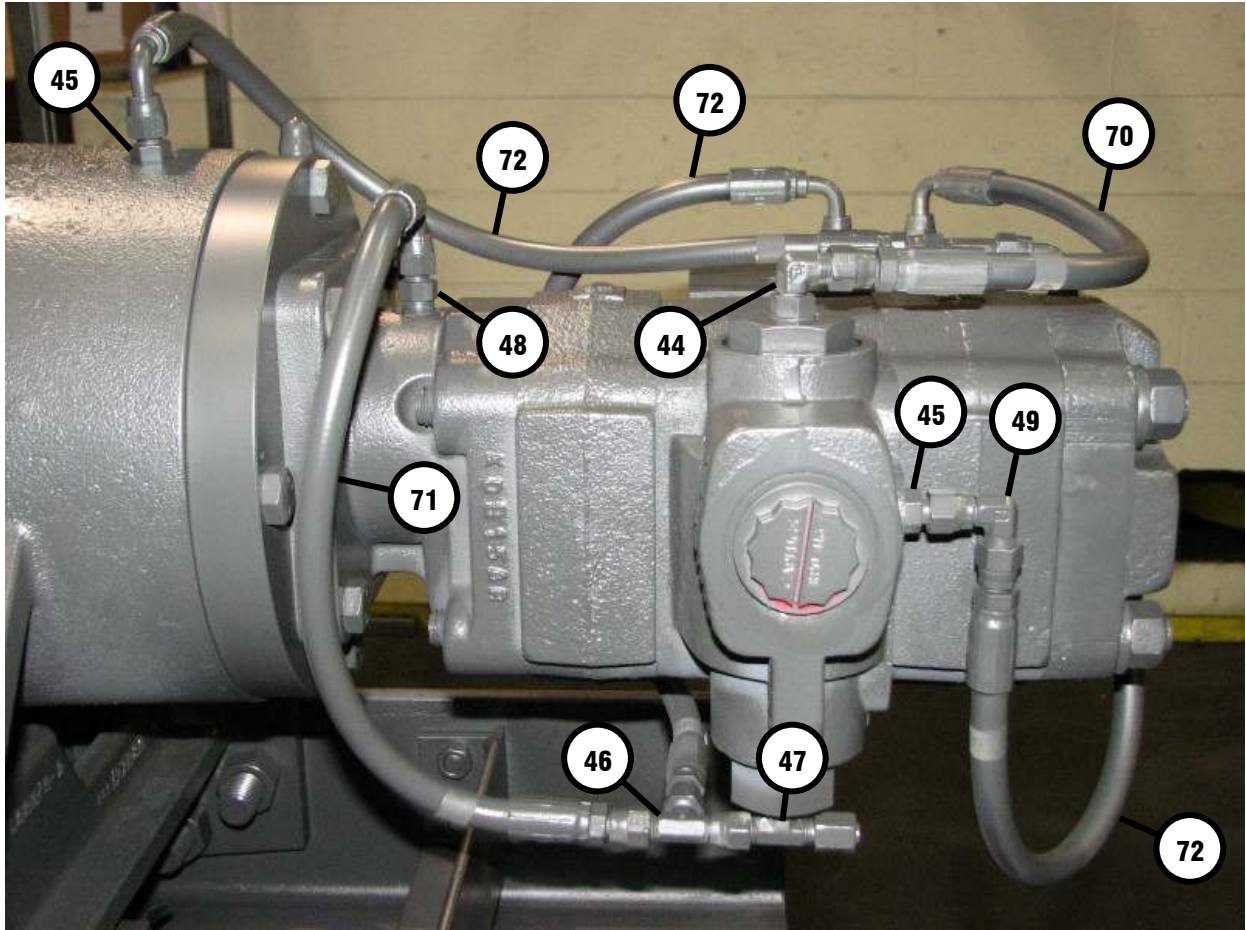

PARTS DRAWING

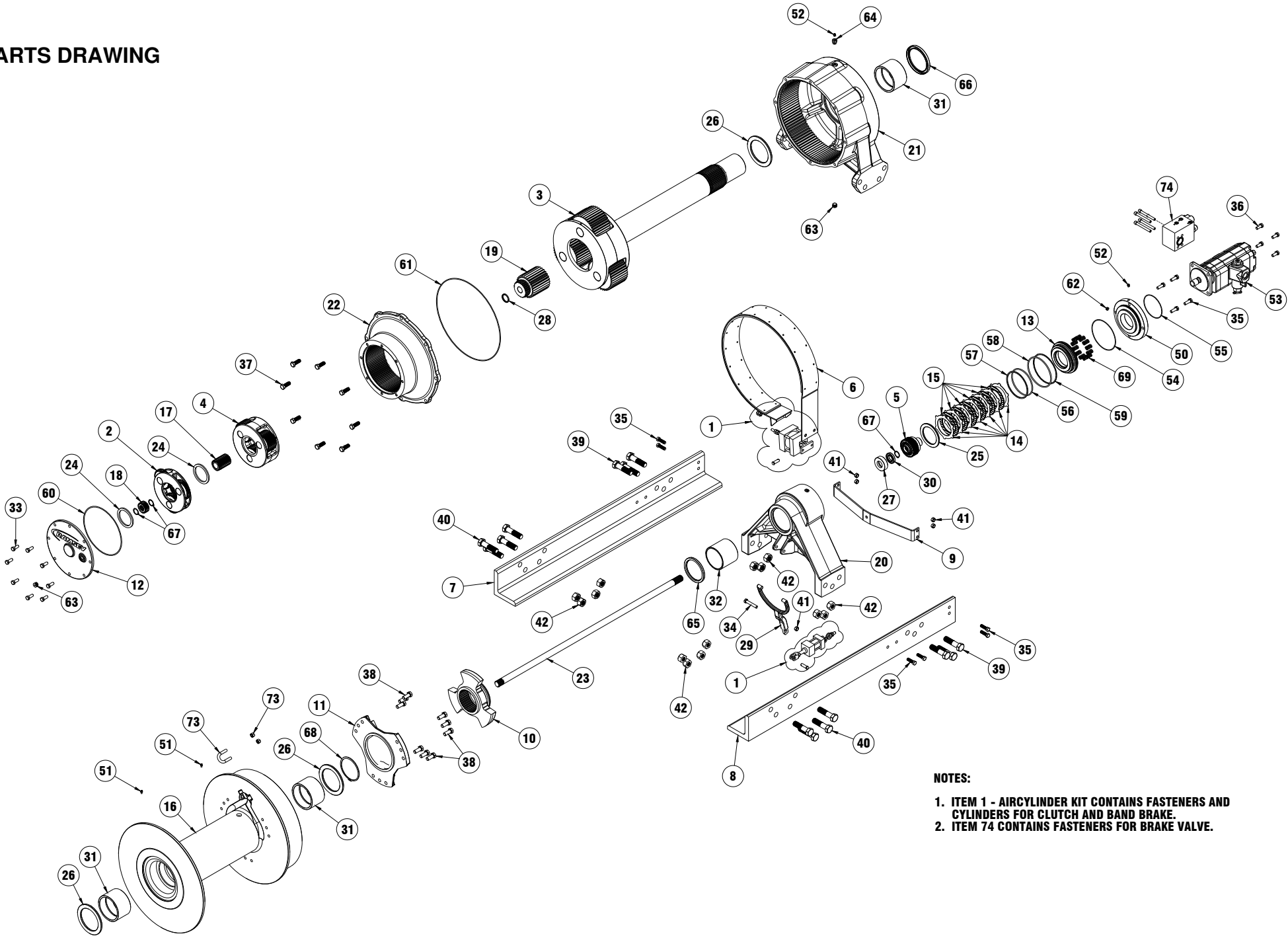

NOTES:
 1. ITEM 1 - AIRCYLINDER KIT CONTAINS FASTENERS AND CYLINDERS FOR CLUTCH AND BAND BRAKE.
 2. ITEM 74 CONTAINS FASTENERS FOR BRAKE VALVE.

PARTS LIST

ITEM	QTY	PART NO	DESCRIPTION	ITEM	QTY	PART NO	DESCRIPTION
1	1	256131	AIR CYLINDER KIT	38	9	414665	BOLT-5/8-11NCX2LG,HXHD,Z/P,GR.5
2	1	296672	INPUT CARRIER ASSEMBLY	39	6	414814	BOLT- 1-8NC X 4.5 LG, HXHD, GR8
3	1	296693	OUTPUT CARRIER ASSEMBLY	40	8	414815	BOLT- 1-8NC X 4 LG, HXHD, GR8
4	1	296694	INTERMEDIATE CARRIER ASSEMBLY	41	5	418069	NUT-1/2-13NC HEX REG
5	1	296952	SPRAG BRAKE ASSEMBLY	42	14	418115	NUT-1-8NC HEX REG
6	1	299752	BAND BRAKE				
7	1	303160	FRAME RAIL-LH	44	1	432018	FITTING JIC O-RING EL
8	1	303161	FRAME RAIL-RH	45	4	432023	FITTING JIC O-RING NIPPLE
9	1	312576	SUPPORT BRACKET, AIR CYLINDER	46	1	432048	FITTING JIC SWIVEL TEE
10	1	324513	CLUTCH	47	2	432049	FITTING JIC BRANCH TEE
11	1	324515	DRUM DRIVER	48	1	432053	FITTING JIC PIPE NIPPLE
12	1	328175	COVER-GEAR END	49	1	432054	FITTING JIC SWIVEL EL
13	1	330016	PISTON-BRAKE	50	1	438043	BRAKE COVER
14	7	330017	STATOR PLATE-BRAKE	51	2	456001	LUBE FITTING
15	6	330018	FRICTION PLATE-BRAKE	52	2	456008	RELIEF FITTING
16	1	332254	DRUM	53	1	458177	MOTOR
17	1	334226	GEAR-INTERMEDIATE SUN	54	1	462063	O-RING 2-165
18	1	334227	GEAR-INPUT SUN	55	1	462081	O-RING 2-159
19	1	334232	GEAR-OUTPUT SUN	56	1	462082	O-RING 2-358
20	1	338404	BEARING SUPPORT, MOTOR END	57	1	462083	BACKUP RING 8-357
21	1	338405	BEARING SUPPORT-GEAR END	58	1	462084	O-RING 2-362
22	1	338411	RING GEAR	59	1	462085	BACKUP RING 8-362
23	1	357539	SHAFT-INPUT	60	1	462093	O-Ring 2-275
24	2	362301	SPACER	61	1	462097	ORING 2 -284
25	1	362305	SPACER-BRAKE	62	1	468016	PIPE PLUG
26	3	362319	SPACER-OUTPUT SHAFT	63	2	468041	PLUG
27	1	362323	SPACER-BEARING	64	1	468042	REDUCER
28	1	362324	SPACER-OUTPUT SUN	65	1	486099	OIL SEAL
29	1	370062	YOKE-CLUTCH	66	1	486100	OIL SEAL
30	1	402142	BEARING BALL	67	3	490068	RETAINING RING 5100-125
31	3	412143	BUSHING-DRUM	68	1	490069	RETAINING RING 5100-500
32	1	412144	BUSHING-MOTOR END	69	12	494129	BRAKE SPRING
33	8	414521	CAPSCREW-1/2-13NCX1LG HXHD	70	1	509137	HOSE
34	1	414545	CAPSCREW-1/2-13NCX3.5LG,HXHD,Z/P,GR.5	71	1	509140	HOSE
35	10	414556	BOLT-1/2-13NCX1.75,HXD,GR5	72	3	509141	HOSE
36	4	414561	CAPSCREW-1/2-13NCX1.25 HXHD GR.5	73	1	514023	U-BOLT
37	8	414658	BOLT-5/8-11NCX1.5LG,HXHD,Z/P,GR.5	74	1	516048	BRAKE VALVE

AIR CYLINDER KIT #256131 PARTS LIST

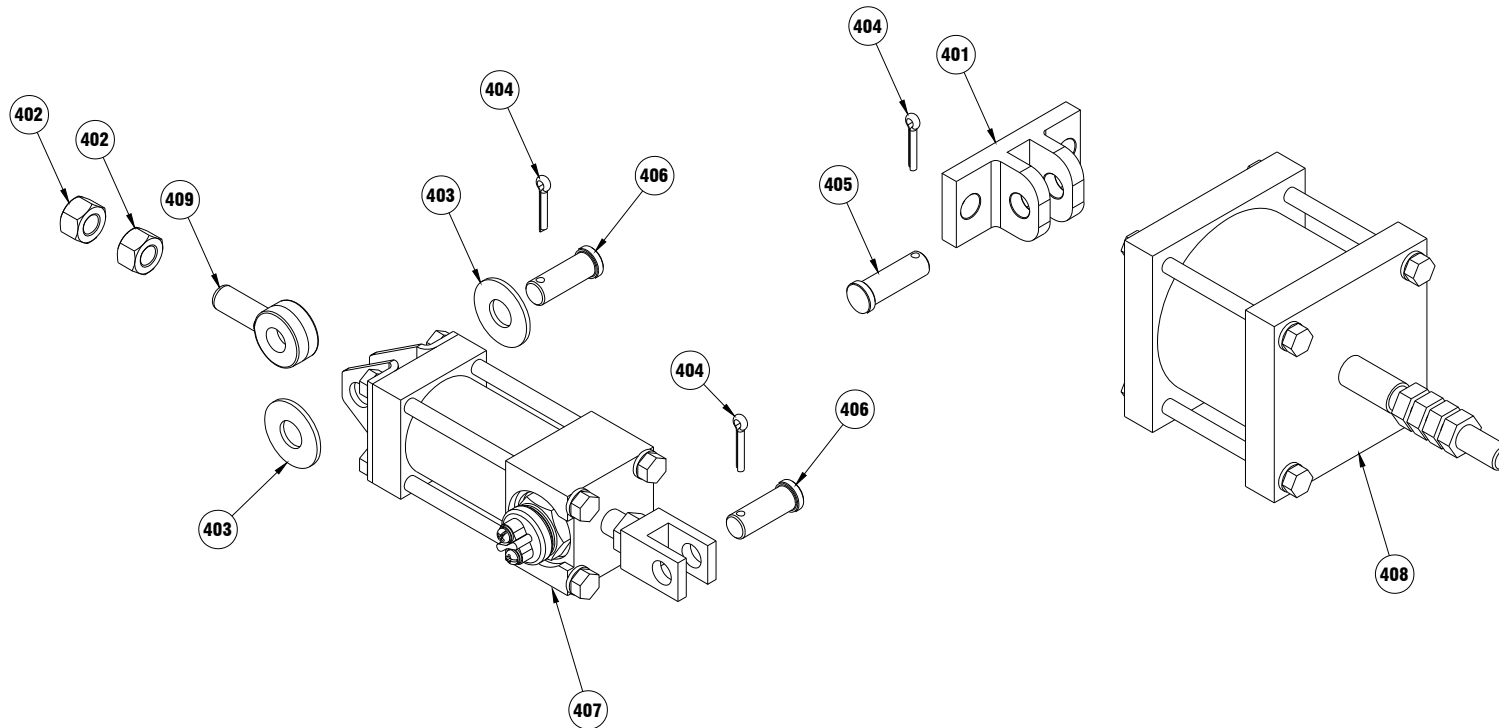

ITEM	QTY	PART NO	DESCRIPTION
401	1	408422	MOUNTING BRACKET
402	2	418067	NUT-1/2-20NF HEX JAM
403	2	418223	WASHER-1/2 USS FLAT
404	3	424005	COTTER PIN- 1/8 DIA X 1 LG
405	1	424027	CLEVIS PIN-1/2 SHAFT DIA X 1 1/2 LG
406	2	424205	CLEVIS PIN-1/2 SHAFT DIA X 1 23/64 LG
407	1	433031	AIR CYLINDER
408	1	433032	AIR CYLINDER
409	1	448108	EYE BOLT

DIMENSIONAL DRAWING

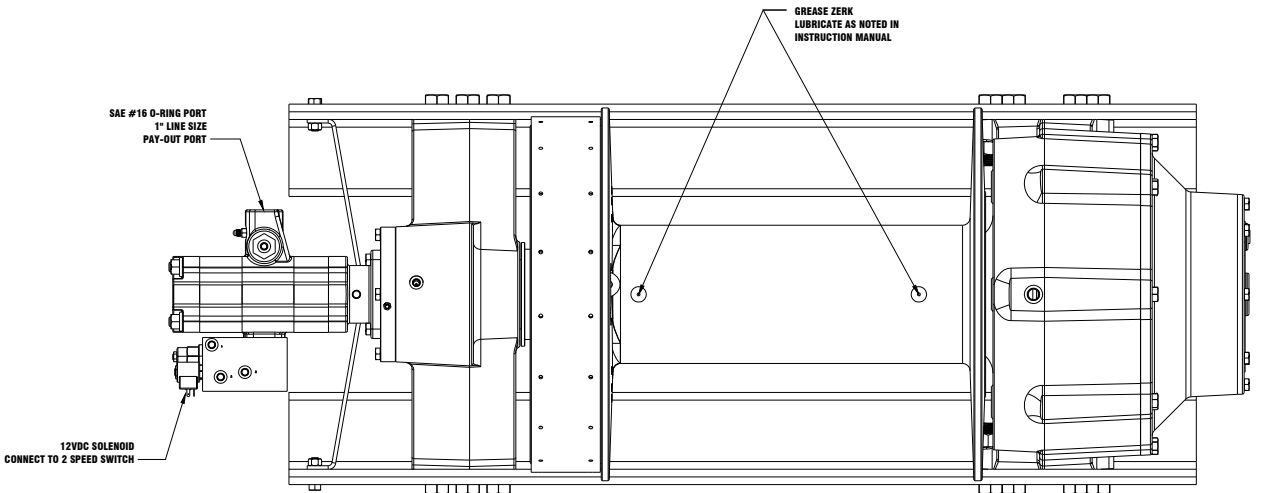

Bolt Size (inches)	Thds Per Inch	Bolt Torque (ft-lb)	
		SAE Grade 5	SAE Grade 8
7/16	14	54	78
1/2	13	78	119
5/8	11	154	230
3/4	10	257	380
7/8	9	382	600
1	8	587	700

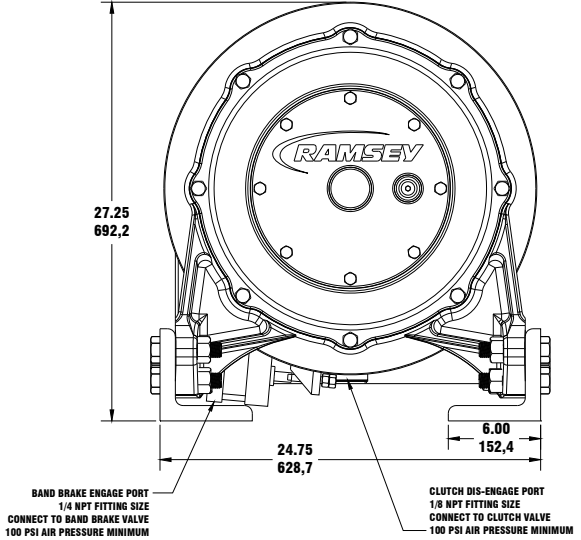
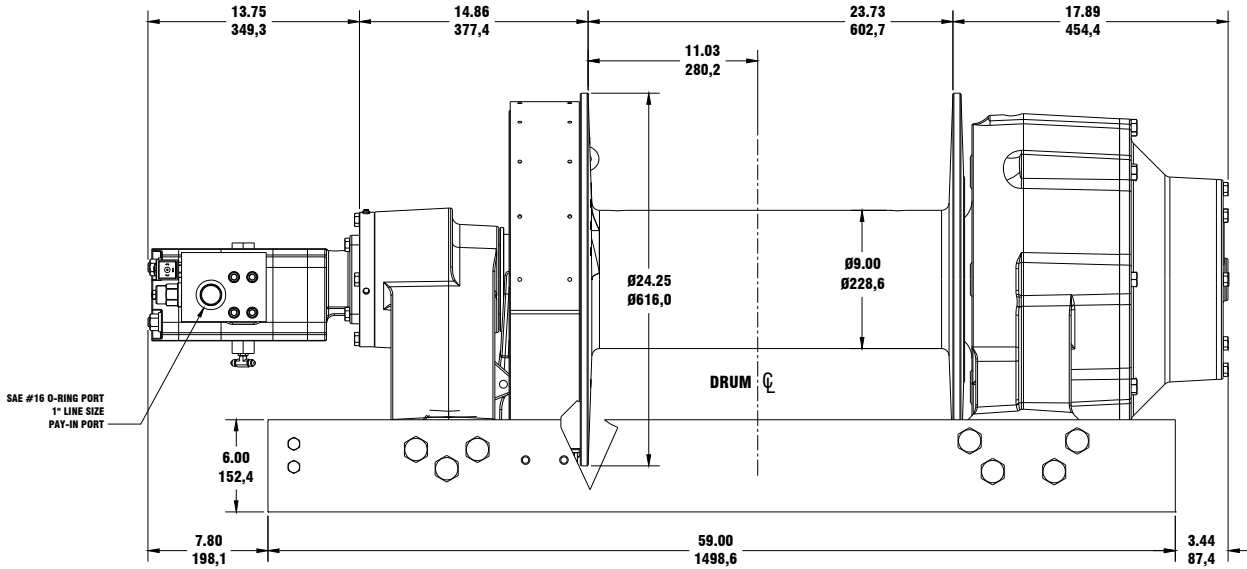



WILDCAT WINCH SERIES

By 

Limited Warranty

RAMSEY WINCH warrants each new RAMSEY WINCH to be free from defects in material and workmanship for a period of one (1) year from date of purchase.

The obligation under this warranty, statutory or otherwise, is limited to the replacement or repair at the Manufacturer's factory, or at a point designated by the Manufacturer, of such part that shall appear to the Manufacturer, upon inspection of such part, to have been defective in material or workmanship.

This warranty does not obligate RAMSEY WINCH to bear the cost of labor or transportation charges in connection with the replacement or repair of defective parts, nor shall it apply to a product upon which repair or alterations have been made, unless authorized by Manufacturer, or for equipment misused, neglected or which has not been installed correctly.

RAMSEY WINCH shall in no event be liable for special or consequential damages. RAMSEY WINCH makes no warranty in respect to accessories such as being subject to the warranties of their respective manufacturers.

RAMSEY WINCH, whose policy is one of continuous improvement, reserves the right to improve its products through changes in design or materials as it may deem desirable without being obligated to incorporate such changes in products of prior manufacture.

If field service at the request of the Buyer is rendered and the fault is found not to be with RAMSEY WINCH's product, the Buyer shall pay the time and expense to the field representative. Bills for service, labor or other expenses that have been incurred by the Buyer without approval or authorization by RAMSEY WINCH will not be accepted.

See warranty card for details.



Ramsey Winch Company

Post Office Box 581510

Tulsa, Oklahoma 74158-1510

Telephone: (#918) 438-2760 FAX: (#918) 438-6688