



Tulsa Winch

1000 & 1200 SERIES WINCHES



- Rated at 11,000 and 13,000 pounds first layer linepull.
 - Ideal for equipment trailers, garbage packers, utility trucks, wreckers, oilfield “hotshot” trucks, pipeline welders, farm vehicles.
 - Direct mount hydraulic flanges eliminate the cost and space required with conventional adapters.
 - Multiple disc oil brake for really severe jobs.
 - More efficient worm gear sets and high speed angular contact bearings allow faster input speeds and higher line speeds.
 - Aluminum housing and end brackets provide high strength while keeping unit weights light.
 - A positive locking clutch shifter handle with a 90° throw for good visual inspection.
-

Installation Dimensions

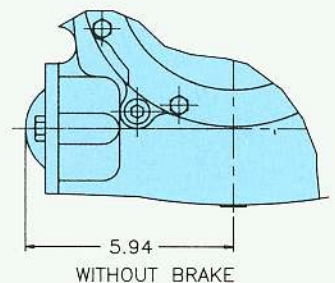
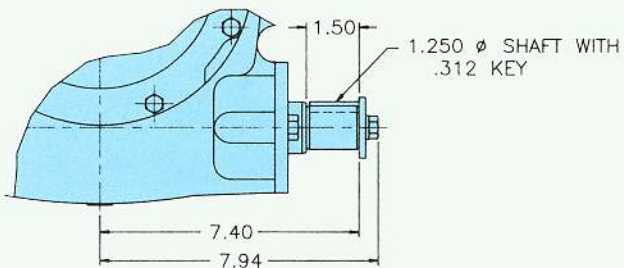
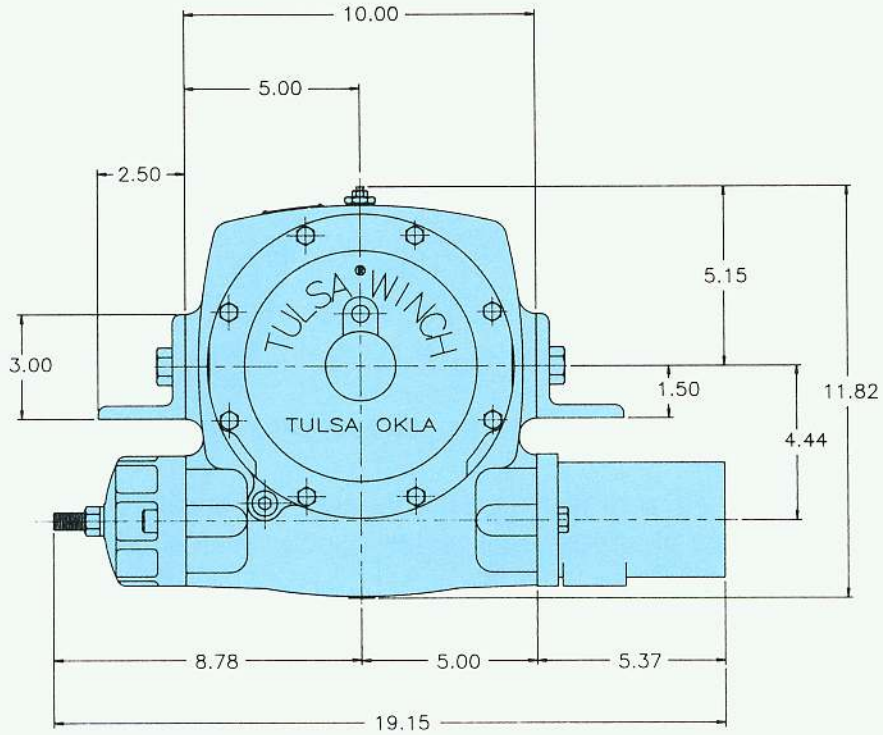
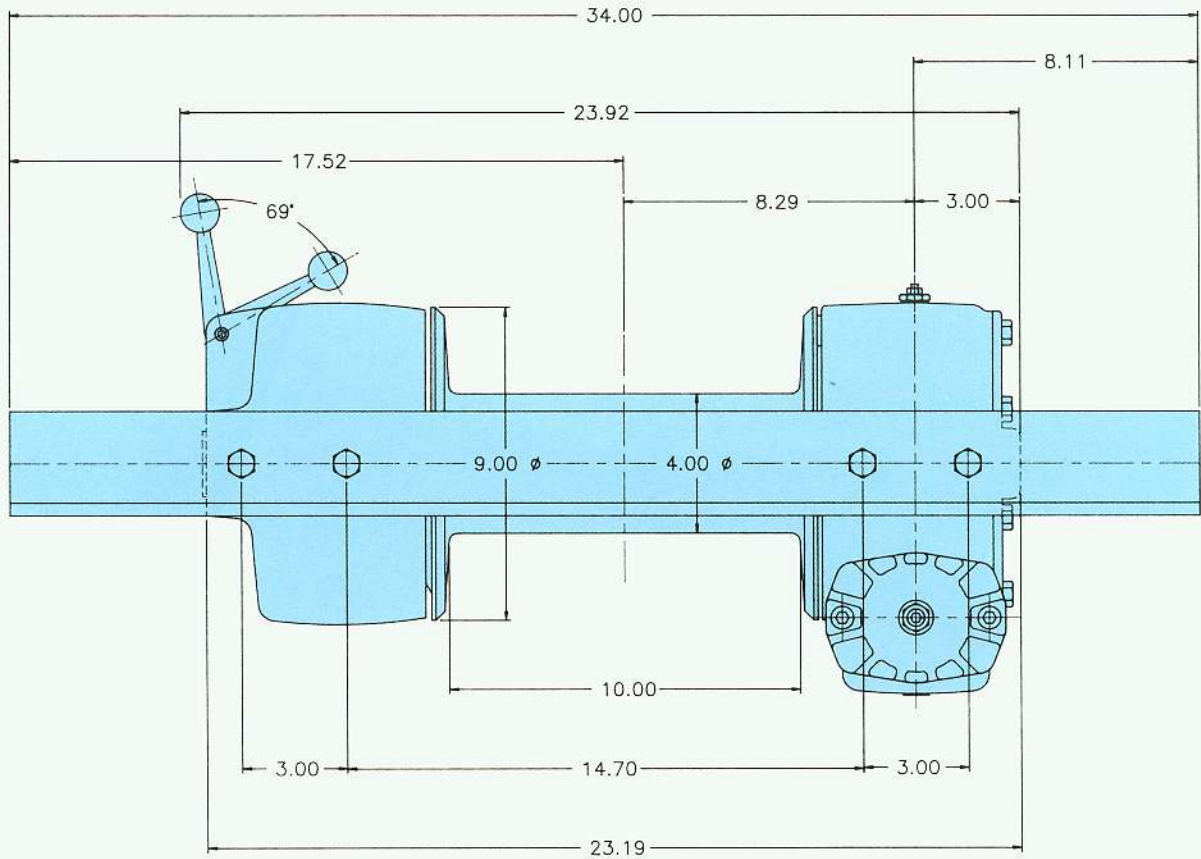

Specifications

	Safe Working Capacity Pounds	Ratio	Max. Input Speed (RPM)	Max. Run Torque (in. lb.)	Weight Pounds
Model 1000	11,000	60:1	1200	793	158
Model 1200	13,000	42:1	800	1309	159

Cable Capacity in Feet

	1st Layer	2nd Layer	3rd Layer	4th Layer	5th Layer
Model 1000 (7/16" Cable)	23	50	82	119	160
Model 1200 (1/2" Cable)	21	47	77	113	

H1060 WINCH—FIRST LAYER PERFORMANCE PRESSURE (PSI)

FLOW
(GPM)

	200	400	600	800	1000	1200	1400	1600	1800	2400
2	690 2.5	1,476 2.4	2,271 2.4	2,664 2.3	3,759 2.3	4,524 2.2	5,211 2.1	5,956 2.0	6,616 1.9	8,235 1.3
4	767 4.9	1,695 4.9	2,593 4.9	3,072 4.8	4,412 4.8	5,293 4.7	6,149 4.6	7,041 4.5	7,861 4.3	10,158 3.7
6	804 7.4	1,774 7.4	2,777 7.4	3,321 7.3	4,811 7.2	5,764 7.1	6,734 7.0	7,680 6.9	8,634 6.8	11,286 6.2
8	746 9.8	1,760 9.8	2,833 9.8	3,427 9.8	4,990 9.7	6,026 9.6	7,071 9.5	8,106 9.4	9,142 9.2	12,224 8.6
10	694 12.3	1,718 12.3	2,851 12.3	3,448 12.2	5,090 12.1	6,220 12.0	7,291 11.9	8,368 11.8	9,491 11.6	12,808 11.1
12	566 14.8	1,648 14.8	2,856 14.8	3,440 14.7	5,135 14.6	6,327 14.5	7,429 14.3	8,550 14.2	9,703 14.1	13,099 13.4
14	425 17.2	1,518 17.2	2,740 17.2	3,422 17.1	5,086 17.0	6,319 16.9	7,475 16.8	8,667 16.6	9,856 16.5	13,407 15.7
15	377 18.5	1,443 18.5	2,664 18.4	3,375 18.3	5,049 18.2	6,299 18.1	7,455 18.0	8,671 17.8	9,886 17.7	13,549 16.9
17	224 20.9	1,293 20.9	2,531 20.9	3,322 20.7	4,964 20.7	6,254 20.6	7,458 20.4	8,672 20.3	9,947 20.1	

TOP NUMBER
IS LINEPULL

BOTTOM
NUMBER IS
LINESPEED

CL H, 3.6 CU.IN.

FOR LAYER NUMBER	MULTIPLY	
	LINEPULL BY	LINESPEED BY
2	0.835	1.197
3	0.717	1.394
4	0.628	1.592
5	0.559	1.789

Model Code

H 1060 - S R R F O - D CL

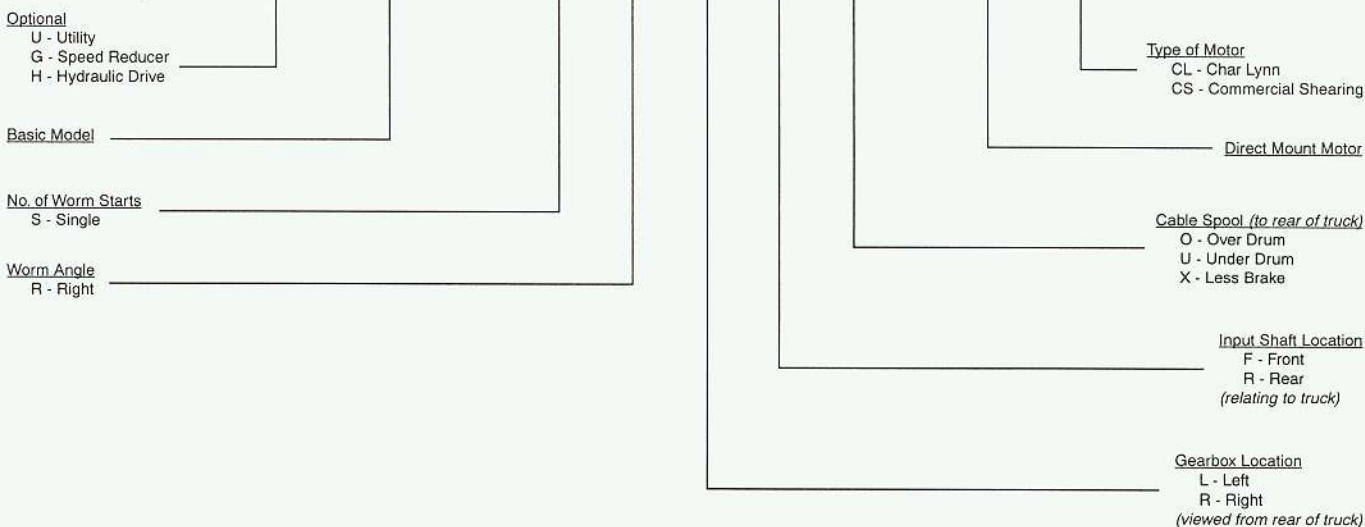

H1242 WINCH—FIRST LAYER PERFORMANCE PRESSURE (PSI)

**FLOW
(GPM)**

	200	400	600	800	1000	1200	1400	1600	1800	2400
2	900 2.2	1,962 2.1	2,969 2.1	3,984 2.0	5,012 2.0	5,904 1.9	6,922 1.8	7,940 1.7	8,740 1.5	10,860 0.9
4	1,000 4.4	2,145 4.3	3,328 4.3	4,550 4.2	5,654 4.2	6,807 4.1	7,984 4.0	9,017 3.9	10,170 3.8	13,209 3.2
6	1,042 6.6	2,225 6.5	3,515 6.5	4,863 6.5	6,126 6.4	7,381 6.3	8,643 6.2	9,803 6.1	11,120 5.9	14,393 5.3
8	963 8.8	2,153 8.7	3,571 8.7	4,923 8.6	6,246 8.6	7,594 8.5	8,899 8.4	10,173 8.3	11,573 8.2	15,484 7.5
10	877 10.9	2,099 10.9	3,563 10.9	4,899 10.8	6,353 10.7	7,807 10.7	9,090 10.5	10,455 10.5	11,861 10.3	16,216 9.7
12	724 13.1	2,049 13.1	3,553 13.0	4,906 13.0	6,400 12.9	7,902 12.8	9,269 12.7	10,651 12.6	12,134 12.5	16,579 11.8
14	579 15.3	1,900 15.3	3,454 15.2	4,934 15.1	6,368 15.1	7,964 15.0	9,359 14.9	10,846 14.8	12,400 14.6	16,868 14.0
15	507 16.4	1,843 16.4	3,374 16.3	4,815 16.2	6,333 16.1	7,967 16.1	9,342 16.0	10,924 15.8	12,442 15.7	17,102 15.0
18	250 19.7	1,571 19.6	3,107 19.6	4,546 19.5	6,244 19.4	7,878 19.3	9,384 19.2	11,069 19.1	12,660 18.9	

TOP NUMBER IS LINEPULL

BOTTOM NUMBER IS LINESPEED

CL H, 5.9 CU.IN.

FOR LAYER NUMBER	MULTIPLY	
	LINEPULL BY	LINESPEED BY
2	0.818	1.222
3	0.692	1.444
4	0.600	1.667