

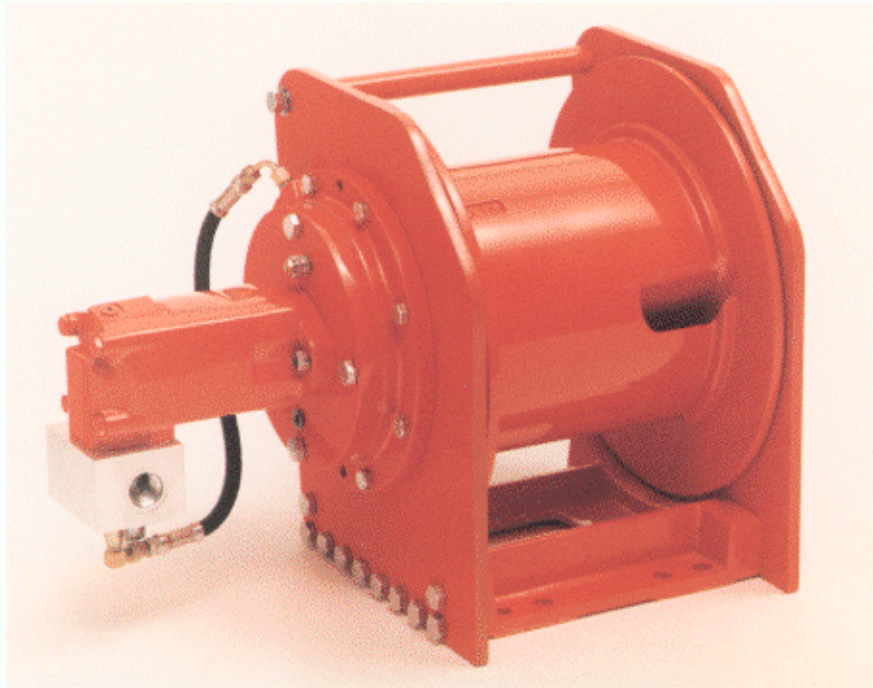

Tulsa Winch

MODEL 707W WINCH



- Rated at 7,000 Pounds First Layer Linepull.
- Applications include truck-mounted cranes, rough-terrain cranes, drilling rigs, offshore cranes and fishing vessels.
- Available with multiple motor options to provide optimum linespeed and linepull for your application.
- Integral spring-applied, hydraulically-released brake for static load holding. The brake has its own oil cavity to insure long life, positive clutch engagement.
- A motor-mounted brake valve provides positive dynamic braking.
- The cable drum is mounted on large-capacity ball bearings for smooth operation.
- Designed for easy servicing.

INSTALLATION DIMENSIONS

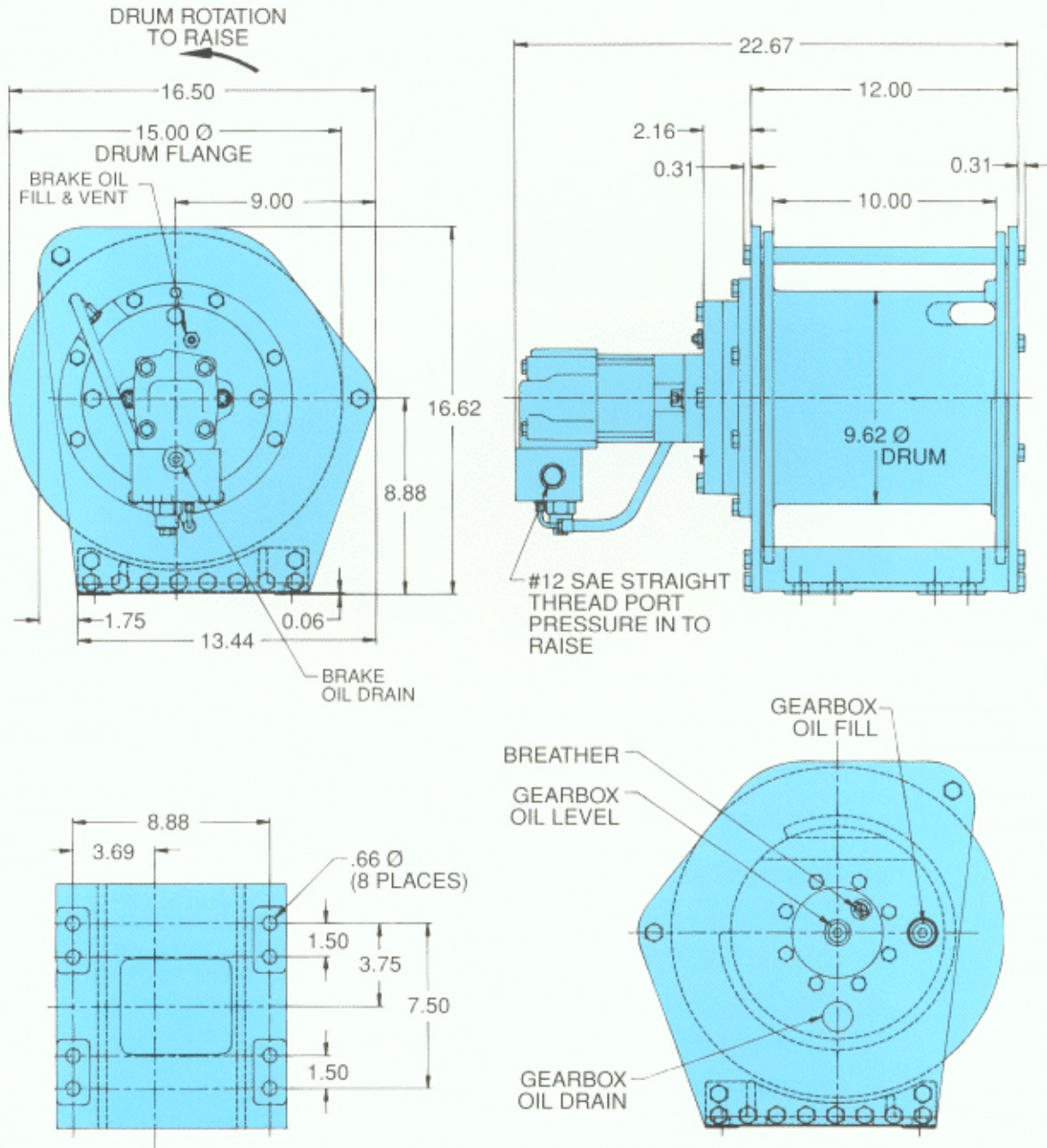

Cumulative Cable Capacity (Feet)

Layer	1/2" Rope	9/16" Rope
1	48	41
2	100	86
3	157	136
4	219	190
5	286	—

Fourth Layer Meets ANSI Freeboard Requirements

PERFORMANCE DATA

With 14.9 cu.in. Motor
PRESSURE (PSI)

FLOW (GPM)

	250	500	750	1000	1250	1500	1750	2000	2250	2500	2750	3000	3250
0.5	511 2	1060 1											
1	561 6	1159 5	1770 5	2306 4	2892 4	3465 4	4051 3	4550 2	5111 2	5659 2	6208 2	6769 1	7317 1
2	573 11	1197 11	1820 11	2368 10	2992 10	3565 9	4164 9	4712 8	5385 8	5946 7	6495 7	7056 6	
4	586 24	1247 23	1920 23	2468 22	3129 21	3752 21	4338 20	4961 19	5547 19	6121 19	6707 19	7292 18	
6	573 36	1271 36	1932 35	2543 34	3216 33	3877 33	4475 32	5136 31	5709 30	6295 29	6881 28		
8	573 48	1259 48	1945 47	2593 47	3278 45	3952 45	4575 44	5248 43	5834 42	6432 41	7018 40		
10	548 60	1247 60	1932 59	2630 58	3303 58	3989 57	4650 56	5298 55	5896 54	6495 53	7130 53		
12	511 73	1197 72	1907 72	2618 71	3291 70	3977 69	4687 68	5310 67	5909 66	6507 65	7143 66		
14	474 85	1134 84	1870 84	2593 83	3241 83	3939 82	4687 81	5273 79	5871 78	6470 77			
16	424 97	1072 97	1820 96	2543 96	3204 95	3889 94	4662 93	5211 92	5809 90	6407 88			
18	362 109	1010 109	1770 109	2493 108	3141 107	3814 106	4612 105	5148 104	5747 102	6345 100			
20	312 122	997 121	1683 120	2381 119	3067 118	3752 118	4525 116	5123 115	5747 114				
22	249 134	885 133	1621 133	2331 132	2979 131	3665 130	4438 129	4999 128	5622 126				
24	187 146	835 146	1546 145	2231 144	2904 143	3590 142	4313 141	4936 139	5560 136				
25	150 152	823 152	1508 151	2181 150	2867 149	3565 148	4251 147	4924 145	5572 143				
30		648 182	1346 182	2019 181	2718 180	3391 179	4064 178	4724 176					

With 18.7 cu.in. Motor
PRESSURE (PSI)

FLOW (GPM)

	250	500	750	1000	1250	1500	1750	2000	2250	2500
1	623 2	1309 1								
2	760 5	1471 4	2181 4	2904 4	3578 4	4288 4	4899 3	5497 2	6108 1	6707 1
3	773 9	1508 9	2244 9	2992 9	3702 9	4375 8	5049 8	5734 7	6407 7	7080 6
4	848 19	1558 19	2344 19	3116 19	3889 19	4600 18	5310 17	6033 17	6744 16	7454 15
6	773 29	1583 29	2393 28	3191 28	4026 28	4749 27	5472 26	6195 25	6931 24	
8	748 39	1583 39	2418 38	3241 38	4101 38	4837 37	5572 36	6320 34	7056 33	
10	711 49	1558 48	2418 48	3254 47	4126 47	3640 46	5647 45	6420 43	7180 42	
12	661 58	1521 58	2393 57	3241 57	4114 56	4887 56	5647 54	6420 53	7180 51	
14	598 68	1471 68	2331 67	3191 66	4064 66	4862 65	5622 63	6382 62	7143 60	
16	536 77	1396 77	2269 77	3116 76	4001 75	4824 74	5585 72	6333 70	7093 69	
18	461 87	1321 87	2194 86	3042 86	3914 85	4737 84	5510 82	6295 80		
20	399 97	1222 97	2094 96	2942 95	3802 94	4625 93	5447 91	6258 89		
22	299 107	1147 107	2019 106	2867 105	3727 104	4438 103	5223 102	6008 101		
24	224 117	1085 116	1932 116	2792 114	3640 114	4263 113	5011 112	5772 111		
25	187 122	1047 121	1895 120	2742 120	3603 118	4164 118	4899 116	5634 116		
30		848 144	1695 143	2543 142	3391 141	3914 141	4749 139			

Top number in each block is linepull in pounds.

Bottom number in each block is linespeed in feet per minute.

Performance shown is first layer with 9/16" wire rope. For additional layers, use factors below.

Layer	Linepull	Linespeed
2	0.90	1.11
3	0.82	1.22
4	0.75	1.33

For 1/2" wire rope, use factors below.

Layer	Linepull	Linespeed
1	1.01	0.99
2	0.92	1.09
3	0.84	1.19
4	0.78	1.29
5	0.72	1.39

Winches and Speed Reducers Known Around the World for Quality

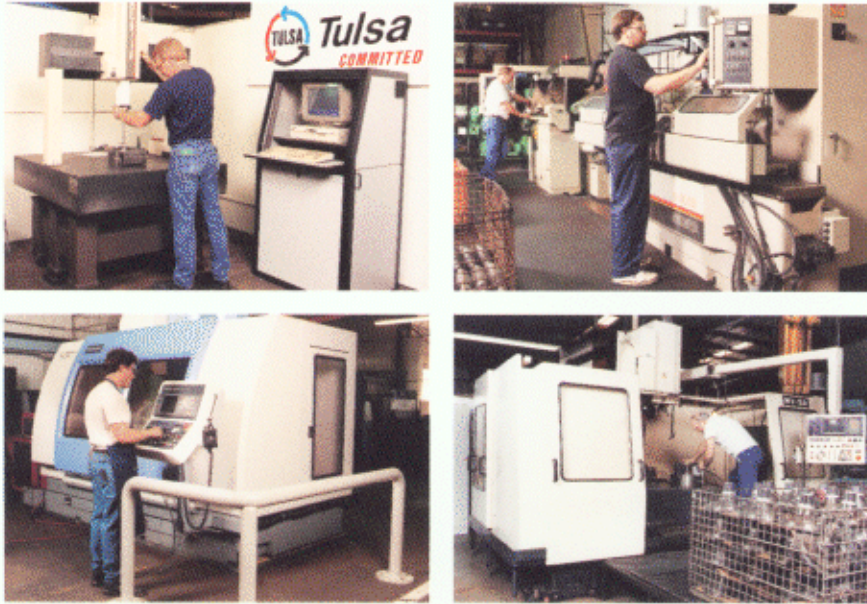

Since its first winch went into service in 1929, Tulsa Winch has built a national and international reputation for top quality winches and speed reducers.

Today, the company manufactures and markets a wide variety of products from a modern 53,000-square-foot plant in Tulsa, Oklahoma. To maintain its high standards, the company has invested heavily in state-of-the-art inspection equipment to assure that every part is made to exacting specifications. Its formal quality assurance program also includes inspection and calibration for both company and employee-owned gauges. Even more significant is the fact that every employee, regardless of job title, is assigned responsibility as a Quality Inspector.

The Tulsa Winch plant utilizes a unique "cell concept" which allows parts to be moved from one machine to another without unnecessary handling and delays. The company has an aggressive machine tool acquisition program and utilizes the latest in computerized machining technology to enhance its customer service capabilities.

In-house computer-aided design and drafting capabilities allow the company to produce the highest quality products possible while being unusually responsive to customer requests for modifications.

Tulsa's test facility features a 100-HP hydraulic power supply, electronic linepull and linespeed measuring devices and other specialized pieces of equipment. Its 35-foot tower, which is capable of 110,000-pound lifts, also helps assure that every Tulsa Winch product meets the very highest standards.



For more information on Tulsa Winches, speed reducers and hanger bearings, contact our nearest distributor. Or call or write Tulsa Winch, P.O. Box 471617, Tulsa, Oklahoma 74147-1617.
Telephone: (918) 663-5744. FAX: 627-3221