

# Chelsea® 340 Series

One Speed Forward and Reverse  
Mechanical P.T.O.



## Overview:

The Chelsea 340 Series P.T.O. is another example of why Chelsea P.T.O. technology is the best in the business. This economical workhorse features a cast iron housing and heavy duty ball bearing on the output shaft, giving it a high torque rating and long service life. Chelsea was the first to provide you with an Air shifted forward and reverse speed P.T.O. Its flexible Air shift design allows you to mount the air shift cylinder in the best position for maximum clearance. Torque rating up to 200 Lbs. ft. make this one versatile P.T.O. Take advantage of over 65 years of Chelsea P.T.O. technology to increase performance and lower costs.

- Oil Field
- Logging



## Product Features and Benefits:

### Contact Information:

Parker Hannifin Corporation  
**Chelsea Products Division**  
8225 Hacks Cross Road  
Olive Branch, MS 38654 USA

**Phone: 1-888-PH4-TRUK**  
**(1-888-744-8785)**

**Fax: 1-662-895-1069**  
**chelseacustserv@parker.com**

[www.parker.com/chelsea](http://www.parker.com/chelsea)

- Single low-speed forward and reverse
- Removable cover plate for adjusting backlash
- Shift options include air and lever
- Variety of input gears to cover most applications
- 6-Bolt Mounting Pad
- Product Features and Benefits
- Two Year Warranty



ENGINEERING YOUR SUCCESS.

## Model Number Designation

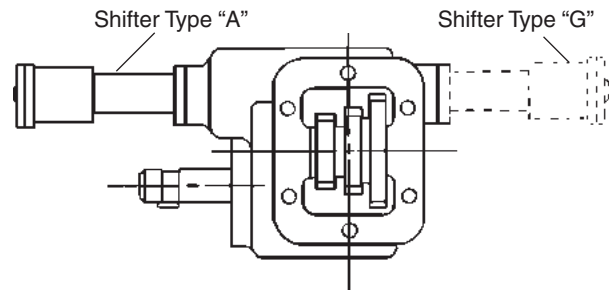
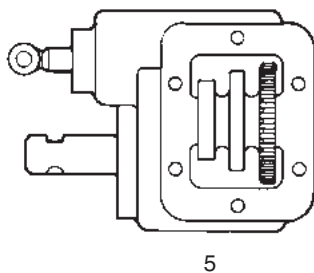
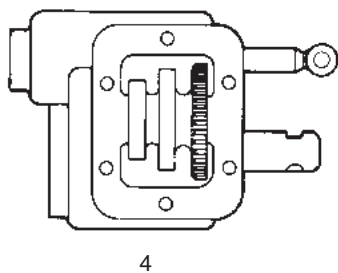
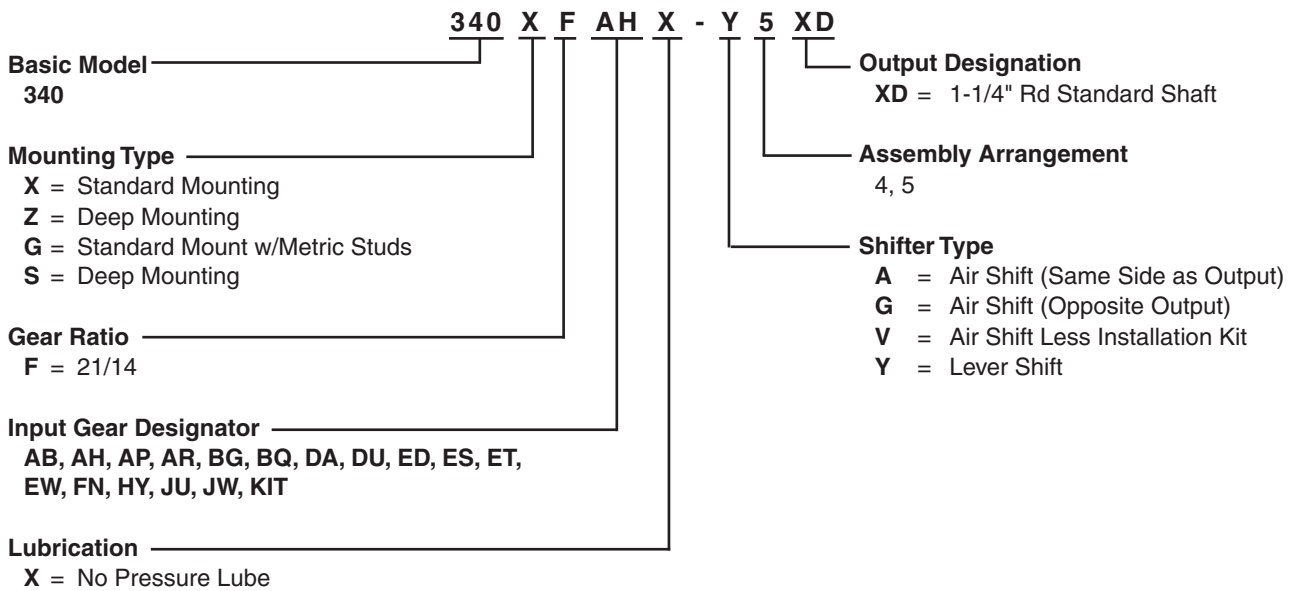

## Specifications Chart – 340 Series

	<b>340*F</b>
Standard Output Shaft Size	————— 1-1/4" Round w/key —————
Intermittent Torque Rating (Lbs. ft.)	200
Intermittent Torque Rating (N.m.)	271
Horsepower Rating for Intermittent Service	
At 500 R.P.M. of Output Shaft (HP)	19
At 1000 R.P.M. of Output Shaft (HP)	38
At 500 R.P.M. of Output Shaft (Kw)	14
At 1000 R.P.M. of Output Shaft (Kw)	28
Approximate Weight:	————— 32 lbs. [15 kg] —————

© 2012 Parker Hannifin Corporation

Supercedes HY25-0106-B1/US June 2010

HY25-0106-B1/US February 2012



**ENGINEERING YOUR SUCCESS.**